



**Saskatchewan**  
Horse Federation

**2024**

# **Heritage Circuit & Prairie Cup Handbook**



Revised January 2024

Saskatchewan Horse Federation  
300-1734 Elphinstone Street  
Regina, SK S4T 1K1  
Phone 306-780-9490  
Fax 306-525-4041  
Web [saskhorse.ca](http://saskhorse.ca)

**The 2024 online handbook shall supersede any discrepancies in the printed edition.**

**Authorized use of the SHF Handbook is granted only to SHF sanctioned events. It is the responsibility of the event organizers and/or people in charge of the event to make sure their event is SHF sanctioned and approved for SHF handbook use. Unsanctioned events should not include advertising/reference of the SHF handbook or sanctioning in any promotional materials or exhibitor information. (August 6, 2024)**



2024

# Heritage Circuit Handbook

Revised January 2024

Visit [www.saskhorse.ca/rulebooks](http://www.saskhorse.ca/rulebooks) for Changes Visible Version



**Saskatchewan**  
Horse Federation

Saskatchewan Horse Federation

300–1734 Elphinstone Street

Regina, SK S4T 1K1

Phone: 306-780-9490

Fax: 306-525-4041

[www.saskhorse.ca](http://www.saskhorse.ca)

# Heritage Circuit - Table of Contents

Our Mission .....	4
Aims, Goals & Objectives .....	6
Structure & Committee.....	7
Animal Welfare.....	8
Guidelines for Show Committees.....	11
Administrative Rules .....	13
Safety & Risk Management .....	16
Protests & Complaints .....	20
Officials .....	21
Saskatchewan Districts for Sport, Culture & Recreation .....	23
Heritage Circuit Divisions.....	24
Heritage Awards .....	26
Point Tabulation & Qualifying Rules.....	28
Rules of Competition .....	33
Western Performance Division.....	39
Western Pleasure .....	40
Reining .....	41
Western Riding .....	63
Trail .....	71
Speed Division.....	78
Barrel Race .....	81
Pole Bending .....	82
Keyhole Race .....	83
Stake Race .....	83

Hack Division.....	85
English Pleasure . . . . .	86
Road Hack . . . . .	87
Show Hack . . . . .	88
Dressage Division .....	89
Western Dressage Division .....	95
Hunter Division.....	97
Hunter Under Saddle Class . . . . .	104
Miscellaneous Hunter Class . . . . .	105
Equitation Division .....	111
Western Horsemanship . . . . .	111
Showmanship at Halter . . . . .	115
English Equitation . . . . .	118
Hunt Seat Over Fences . . . . .	121
<b>Ranch Division .....</b>	<b>123</b>
<b>Working Western Rail . . . . .</b>	<b>123</b>
<b>Ranch Riding . . . . .</b>	<b>123</b>
<b>Ranch Trail . . . . .</b>	<b>123</b>
Additional Classes .....	124
Pleasure Driving . . . . .	124
Junior Horse Pleasure Classes . . . . .	128
Miscellaneous Classes.....	128
Command Class . . . . .	128
Hunter Hack . . . . .	130

# Our Mission

---

The Saskatchewan Horse Federation delivers value to its members through initiatives in sport, industry, and other equine activities, while upholding standards of equine welfare.

## **A Statement of Principle on Equine Welfare**

The Saskatchewan Horse Federation is the voice and leader in an evolving and sustainable horse industry.

We believe it is the responsibility of the Saskatchewan Horse Federation to set provincial standards for competition that are consistent with federal regulations and that bear the welfare of the horse as a primary concern. **Ethics, fair play, and good sportsmanship form the foundation for all activities that pertain to horse events under the jurisdiction of the SHF.**

**The Saskatchewan Horse Federation (SHF), acting as the accepted Provincial Association for provincial horse groups, supports adherence to humane treatment of horses in all activities under its jurisdiction.**

The standards by which conduct, or treatment will be measured is that which a reasonable person, informed and experienced in generally accepted practices, would determine to be neither cruel nor abusive nor inhumane.

For more information on the code of practice visit <https://www.nfacc.ca/codes-of-practice/equine>

## **The Saskatchewan Horse Federation will:**

- Uphold the welfare of horses, regardless of value, as a primary consideration in all activities.
- Require that horses be treated with kindness, respect, receive good care, and not be subjected to mistreatment.
- Ensure owners, trainers, exhibitors and their agents use responsible care in the handling, treatment, and transportation of horses that are under their care.
- Provide the availability for routine inspection and consultation with health care professionals and industry officials to achieve high practices of nutrition, health, comfort, sanitation, transportation, and safety as provincial standards.

- Support and promote scientific studies on equine health and welfare.
- Offer education in training and horsemanship practices.
- Require owners, trainers, handlers, and exhibitors to know and follow sanctioned rules and regulations and to work within industry standards for equine activities and businesses.
- Review, revise, and develop competition rules and regulations that protect the welfare of horses.

## **Medications Control**

The Saskatchewan Horse Federation reserves the right to introduce drug testing at Heritage Circuit shows in the future. Our intention would be to provide due notice of at least one year to any participating competition and to the membership. However, we are subject to changes in national rules that may not provide for a lengthy notice.

## **Equine Infectious Anemia (EIA)**

**The Saskatchewan Horse Federation strongly recommends that all Heritage Circuit competitions require horses to be tested for EIA. All requirements for testing will follow CFIA\* guidelines.**

\*The Canadian Food Inspection Agency is the regulatory body responsible for disease management in Canada.



# **SASK LOTTERIES**

# Heritage Circuit

## **Aims, Goals & Objectives**

1. Provide, at a provincial level of competition, a circuit of horse events that will increase participation in all areas of the horse sport within the province, (with the exception of racing).
2. Raise the awareness of the horse sport to the general public of Saskatchewan.
3. Educate competitors, show committees, officials, and coaches by standardizing the Rules and Regulations under which they operate.
4. Encourage a broad base of participation at the grassroots level of the sport, increasing entries at agricultural fairs and other permit-level local shows.
5. Enhance the District concept of sport development as designed by Sask. Sport and the Government of Saskatchewan, by organizing competitions on a District basis and awarding recognition to those participants.
6. Ensure a system of delivery for team development.
7. Provide yearly championship awards at the provincial level of competitions.
8. Work with District representatives to ensure horse sport is included in the Saskatchewan Summer Games.
9. Present a program of grassroots competitions that encourages participation in the Long-Term Equestrian Development Model.
10. Provide a competition development pathway for athletes, leading to participation in the Saskatchewan Summer Games, Prairie Cup Series, NRHA, Breed Shows, Provincials, etc.
11. Encourage interest in and to develop officiating within the province.
12. Enhance the image of the Saskatchewan Horse Federation with the general membership by providing a program that is universally available to everyone.
13. Promote a 'Sport for All' concept.

# **Structure & Committee**

---

## **Structure**

The Heritage Circuit Committee is an operational committee of the SHF. The Committee reports to the VP of Sport, Board of Directors, and the Executive Director of the SHF.

## **Heritage Committee Chair**

Appointed by the President and approved by the Board of Directors of the Saskatchewan Horse Federation.

## **Heritage Committee Members**

1. The Prairie Cup Committee will work with the Heritage Circuit Committee to ensure seamless transition between the competition levels.
2. The President of the Saskatchewan Horse Federation is an ex-officio member of all SHF committees.
3. The Health and Welfare Committee shall serve in an advisory capacity.
4. The VP of Finance shall serve in an advisory capacity.
5. The Executive Director and Competition Staff Liaison are also members of this committee and serve in an advisory capacity on all matters pertaining to operational aspects of the Heritage Circuit.
6. Voting representatives on the committee, as chosen by the Committee Chair and approved by the Board, should include representation from:
  - a. Coaching
  - b. Officials
  - c. Competition Organizers
  - d. Western disciplines
  - e. English disciplines

## **Heritage Committee Duties**

1. Update the Heritage Circuit Handbook annually as required, keeping it consistent with the Rules and Regulations under which the Heritage Circuit will operate.
2. Work with the SHF office to update the show package that is sent to show committees each year.

3. Assist the office with tabulating points and records of placings used for awarding year end honors with the Heritage Circuit.
4. Assist in securing sponsorships and donations for the purchase of prizes to be awarded to Heritage Circuit winners each year.
5. Promote and encourage SHF members to nominate to the Heritage Circuit.
6. Assist the SHF office staff with the preparation of interim reports.
7. Assist the SHF office staff with the preparation of an annual report for presentation to the SHF membership at the AGM.
8. Record minutes and motions of all committee meetings and submit to the office of the SHF.

**Any recommendations for policy and program changes to the Heritage Circuit must be presented to the Board of Directors for approval prior to implementation.**

## **Animal Welfare**

The Saskatchewan Horse Federation is dedicated to the humane treatment and welfare of horses. Cruel, abusive, or inhumane treatment of a horse at any SHF competition by an exhibitor, owner, coach/trainer, or other person must not be tolerated anywhere on the grounds under any circumstances. The SHF supports any decision of officials or Show Committees that removes a horse from a competition due to obvious lameness or exhaustion.

Cruelty can be defined as causing pain or unnecessary discomfort to a horse, whether intentional or unintentional. The standard by which such conduct or treatment will be measured is that which a reasonable person, informed and experienced in generally accepted equine training and exhibition procedures, would determine to be cruel, excessive, or inhumane. The exhibiting of a horse in an excessive number of classes during a competition is discouraged and may be deemed as inhumane.

The organizing show committee must bar such violators from further participation in the competition. It is recommended every horse show publish a statement in its prize list regarding its position on the abuse of horses and its commitment to the humane treatment and welfare of horses, with the penalties to be imposed for confirmed abuse of horses at the show.

In any performance event, the judge shall have the authority to request the removal or alteration of any piece of equipment which, in his/her opinion, would give the horse an unfair advantage or which he believes to be inhumane.

## **Important Rules Regarding Equine Welfare**

**Dressage Divisions (English and Western):** A horse/rider may compete in any two, but only two consecutive levels, and a horse may compete in a maximum of four tests per day (combined English and Western), including the Freestyle. It is the Rider's responsibility to make sure that they do not exceed the allowed number of tests per day or year end points may be forfeited in excess of allowance.

**Hunter Divisions:** A horse/rider may compete in any three, but only three consecutive class heights, and a horse may jump a maximum of four over-fence classes per day (combined Hunter and Jumper), including specials, classics, derbies, stakes, medals, or equitation over fences. It is the Rider's responsibility to make sure that they do not exceed the allowed number of over-fence classes per day or year-end points may be forfeited in excess of allowance.

**Individual Work:** An exhibitor may ride up to a maximum of three different horses in any one class requiring individual work. A horse can only compete once in any particular class and cannot be ridden by more than one rider.

# Lameness

1. Obvious lameness in any class or event may be cause for disqualification. The following signs will constitute lameness:
  - Marked head bobbing or nodding at the trot
  - Hitching
  - Shortened stride
  - Minimal weight bearing in motion
  - Inability to move
2. In the event that a horse exhibits one or more of these signs, the judge may choose from the following:
  - To not consider a lame horse for placing
  - To give a lame horse a zero or 'no' score
  - To ask that the horse be excused from a class
3. Horses entered in all events must be in good condition. Horses giving the appearance of being emaciated, sullen, dull, lethargic, or showing recent signs of physical abuse or exhaustion may not be placed in a class. At the Judge's discretion, these cases may be dismissed or disqualified for the remainder of the competition day.

# Guidelines for Show Committees

The Heritage Circuit is a Provincial level of competition that encourages a broad base of participation in horse sport. Show committees are required to administer their licensed competitions in accordance with the Aims, Goals, and Objectives of the Heritage Circuit, with specific attention to ensuring standards of fair play, safety, and equine health and welfare.

1. Prize lists should indicate that the competition is licensed with the SHF and designated as a Heritage Circuit approved event (or dual sanctioned).
2. Prize lists are to include information regarding competition licensing and the nominating process.
3. Classes approved for points should be designated on all advertised prize lists.
4. At least one member of the Show Committee **MUST** be a current SHF Individual Member for liability insurance reasons. Shows failing to comply will not be recognized as a Heritage Circuit Show.
5. Each show will receive Heritage Circuit first place ribbons for each Heritage Circuit class held at their show.
6. Each show will receive a Show License Certificate that must be displayed at the horse show office.
7. Results forms are supplied to the Show Committee secretary and are to be completed for each Heritage class. They must list the placings of all horses from first through fifth place, whether a Heritage Circuit nominated horse or not. Accuracy in reporting results ensures provincial championships are calculated correctly.
8. **Membership:** The SHF strongly recommends all shows ensure competitors are either an SHF Individual Member, or if not from Saskatchewan an Individual Member of their Provincial sport governing body (PTSO) affiliated with Equestrian Canada, or they have their own personal liability insurance. This ensures that each competitor has their own personal liability insurance.
9. **Nominations:** Heritage Shows are encouraged to promote nomination of the rider/horse to the Heritage Circuit, so they will be eligible for year-end awards.

- 10. Youth Sportsmanship Award:** Show Committees are encouraged to solicit and submit nominations for a Heritage Circuit nominated junior competitor who exemplifies good sportsmanship at their event. The name of this person should be submitted to the SHF office by the show committee.
11. Show Committees should ensure that all equipment, show ring, and warm up areas are in good repair and meet required standards. For details on specific class requirements refer to Division/Class rules. Show equipment should be inspected and in place prior to the start of the show.
  12. It is recommended that a full list of equipment be made available to officials prior to the show.
  13. Show Committees should have basic equipment available such as a tape measure, rake, stopwatch, etc.
  14. Shows failing to comply with the above will not receive first place ribbons and will not be recognized as a Heritage Circuit Show.
  15. At the discretion of individual Show Committees, any competitor that is deemed 'not in good standing' by that particular competition committee may be denied entry or refused prizes as set by that competition.
  16. Competition organizers are encouraged to also make their events eligible for other programs and incentives (such as NAERIC Advantage, PAC and TIPS). Contact the SHF office for more details.
  17. It is strongly recommended that competition managers, committee members, and members of their immediate families who compete at competitions they are managing, each declare a conflict of interest and should not be directly involved in paying officials. Declaration of conflict of interest forms are available at the SHF office.
  18. The SHF recommends that at least one member of a Competition Organizing Committee has taken Respect in Sport, an online module available through Sask Sport to everyone, free of charge.  
<http://www.sasksport.sk.ca/RiS/>

# Administrative Rules

---

1. **Handbook: For the current rules of competition and administration, the online version will supersede all printed copies of the handbook.** For the purposes of point tabulation, the competition year for both the Heritage Circuit and Prairie Cup Series will be from November 1st of the previous year to October 31st of the current calendar year.
2. The SHF will supply a first-place ribbon for each Heritage class in all shows participating in the SHF Heritage Circuit. Ribbons will only be provided for SHF Heritage Circuit classes on the approved class list of the current year.
3. **Show Committees must submit applications and a FINAL COPY prize lists at least FOUR WEEKS prior to the show date or a \$25.00 penalty fee may be assessed to the show. Shows submitting late applications must also pay any courier, bus, or extra shipping costs incurred.**
4. Shows are able to dual sanction their horse show to offer both Heritage Circuit and Prairie Cup classes. This will allow riders to easily make the transition to the higher performance levels.
5. Forms for class results and ribbons will be sent to each show after the SHF office receives and approves their permit, sanction, class applications, and prize list.
6. **Show organizers must submit the results of each SHF Heritage Circuit class, along with any nominations or membership applications received at the show. All show organizers must submit the \$50.00 filing fee, or their show will not be sanctioned.** The show organizer can submit a separate cheque for the \$50.00 filing fee which will be destroyed if results are received in the SHF office within 2 weeks from the last day of the show OR the show organizer can pay the \$50.00 filing fee along with all other show permit/sanctioning fees (by e-transfer or credit card) and a refund will be issued if show results are received in the SHF office within 2 weeks from the last day of the show.
7. **Dressage placings AND percentage scores must be submitted to the SHF by show committees on the results forms.**
8. Competition results must be received by October 31st for points to be included in the tabulation for awards.

9. Horse/rider pairs nominated for the Heritage Circuit will begin point accumulation only AFTER the horse/rider combination is nominated. Points earned prior to nomination of horse/rider WILL NOT be considered.
10. Persons may nominate their horse at a show on the form provided or online. To be eligible for awards, a person must be a current Individual Member of the SHF and nominate the horse on which s/he wishes to accumulate points.
11. Riders are able to nominate to both Heritage Circuit and Prairie Cup (dual nominate) and will collect points in each respective circuit.
12. The show must forward all membership applications and nominations it receives to the SHF promptly, to ensure competitors receive their proper points.
13. Once a class has begun (the gate shut, or the first horse judged), no further entries will be accepted at the show office or at the gate.

#### 14. Dressage Division:

- a. **A horse/rider may compete in any two, but only two consecutive levels, and a horse may compete in a maximum of four tests per day (combined English and Western Dressage), including the Freestyle.**
- b. When there is only one horse in a class, ribbons and prizes shall be awarded in accordance with the following percentages:

1st	63% or higher
2nd	60% to 62.9%
3rd	58% to 59.9%
4th	<del>51% to 53.9%</del>
No ribbons or prizes shall be awarded below 3rd position.	

- c. **Heritage Circuit competitions will use Equestrian Canada tests.** If you do not have an EC sanctioned show, you must pay \$1 per test up to a maximum of \$20 to EC for the use of the tests. If you do not have internet access, contact the SHF Office for hard copies.
- d. **In the case of equality of points the competitor with the highest total of collective marks shall be declared the winner. When collective marks are tied, the horses shall remain tied.**

## 15. Western Dressage Division:

- a. A horse/rider may compete in any two, but only two consecutive levels, and a horse may compete in a maximum of four tests per day (combined English and Western Dressage), including the Freestyle.
- b. Heritage Circuit Western Dressage classes will use WSDAC Tests, located at [www.westernstyledressage.ca](http://www.westernstyledressage.ca).
- c. When there is only one horse in a class, ribbons and prizes shall be awarded in accordance with the following percentages: See Chart on Pg. 14 #14 b.

## 16. Hunter Division:

- a. A horse/rider combination may compete in a maximum of three consecutive heights per day.
- b. A horse may compete in a maximum of four over fences classes per day which applies to combined Hunter and Jumper classes including specials, classics, derbies, stakes, medals, or equitation over fence (not including Hunter warm ups, Jumper clear-rounds and hors concours rounds). Hunter classics and hunter specials that are 2 round classes will count as one over fences class. Jumper classes that include a jump off will count as one over fences class.
- c. Hors concours rounds are allowed at the discretion of the judge and/or show committee. Hors concours riders will pay a regular entry fee and will follow all rules pertaining to the competition. They will not be eligible for awards. A horse or pony that has competed "HORS CONCOURS" is not permitted to be judged in the same ring on the same day. A horse or pony may only compete "HORS CONCOURS" once in the same ring on the same day.
- d. A horse is limited to one round per class and may not be ridden by more than one rider in that class.
- e. An exhibitor may ride up to three different horses in any one class.

## Age Categories

1. For SHF Heritage Circuit purposes, a competitor will adhere to the following age groups:
  - a. **Riders must compete in their Age Division, or Open Classes if they choose, as determined by the Year of Birth as it appears on their Birth Certificate.**

Age Division	Year of Birth
Junior C	2012 or later
Junior B	2009 to 2011
Junior A	2006 to 2008
Senior	2005 or earlier

2. Junior ages may be combined to offer one Junior class; or Junior Combined B/C and Junior A; or Junior Combined A/B and Junior C. When classes are combined or split a rider will only earn points in their respective age category.
3. Any class may offer only one Open group.

## Safety & Risk Management

---

The Saskatchewan Horse Federation urges all members to develop a Safety Awareness Program for each of its events for the benefit of the participants, the spectators and the event management involved. The staging of Horse Shows is an activity that is particularly vulnerable to accidents, and therefore the Show Committee has a special responsibility to provide an event that is run as safely as possible.

**No toddlers, or infants (in strollers, snugly, or carried) are allowed in the warm up rings.**

### Safety Committee

It is a requirement for insurance purposes that all Horse Show Committees have a safety sub-committee that has the authority to develop safety policies and procedures for their event and to enforce those regulations.

The Show Committee should:

1. Name a chairperson who is responsible for Safety Precautions during the event.

2. Have the Safety Committee develop, and the Horse Show Committee approve, the safety guidelines for the event. Include development of a Crisis Plan to address unforeseen occurrences such as protocol in the event of severe inclement weather, or an attendee or guest threatening harm to horses and/or riders.
3. Empower the Safety Committee to enforce any rules or regulations relating to the safety guidelines during the event.
4. Record and report to the SHF any untoward incidents or accidents that occur during the staging of the sanctioned event.
5. Record keeping: Accurate records of the event, and any other matters that require documentation, should be kept by the show secretary for not less than two and a half years following the event.
6. Ensure emergency medical attention is available for every event.
7. An Emergency Action Plan should be made available to all officials.

## Liability Waiver

It is recommended all horse shows use an Acknowledgment of Risk and Release of Liability form to be signed by each participant at the event. Do not be deterred by the criticism that waivers 'do not hold up in court' or 'are not worth the paper they're written on'. Every piece of documentation counts when a legal claim is instituted. **It is especially important that you verify that parents/guardians have signed the Acknowledgment of Release form for anyone under the age of 18 years.**

Should people refuse to sign the form, the show committee can refuse to allow them to participate in the event. However, do not coerce persons into signing the waiver. It must be their decision. If they wish to participate in the event, a waiver is a part of the agreement they must undertake.

A sample form is available for use by shows. The Saskatchewan Horse Federation does not make any claims as to the effectiveness of the form.

Every show is advised to consult a lawyer regarding a suitable form for use at their event.

# First Aid & Emergency Medical Help

1. It is essential that every horse show has a plan in place for emergency medical help.
2. A show should have a First Aid Kit readily available at all times for minor incidents. The kit should include a St. John's First Aid Emergency Medical Help reference handbook or similar publication for consultation.
3. A show should have, preferably on hand during the entire event, a person(s) who is trained and knowledgeable in First Aid/Emergency Medical Treatment. Depending on the risk involvement of the particular sport and the availability of medical help, such a person might be a First Responder, a Certified Coach, a registered nurse, an EMT, a Ski Patrol official, or similar other person who has some first aid designation.
  - a. **Ambulance/MD:** If they are not present at the event, ensure the contact information for either or both is readily available in case of emergency. It is advisable to contact them in advance with details of your event in case their services are required.
  - b. For specific safety and medical services required for Hunter Over Fences classes, refer to "Safety/Medical Services" on page 98.
4. A backboard and collar are advisable to have on hand at all show events but must only be used by trained personnel.
5. If a person is rendered unconscious or complaining of back pain, under no circumstances should that person be moved. Wait until qualified medical help is present before moving such a person.
6. If a show is sanctioned under Equestrian Canada rules, the EC Accidents & Return-to-Play Rule is in effect. For more information see [equestrian.ca](http://equestrian.ca) or the Equestrian Canada Rulebook, Section A, General Regulations, Article 101.

## Safety Checklist

1. Make a safety checklist for your show, with a plan of action to ensure safety procedures are followed. Some areas to include:
  - a. Stable and arena safety, warm-up and competition rings
  - b. Spectator areas, seating, parking and walkways

- c. Emergency Action Plan
  - d. Fire precautions, emergency measures and emergency exits
  - e. Contact information for suggested veterinarians and farriers
  - f. Availability of an AED device
2. **Signage:** Post all Emergency Rules and Regulations that participants and spectators are to follow. Use signage to alert persons of any dangers. Be sure to post rules and guidelines for the safety and protection of all youth and vulnerable individuals on the premises, both as participants and as spectators.
3. Other policies to consider:
- a. Unruly horses and/or people
  - b. Alcohol/drugs and their use while on the premises
  - c. Smoking and its non-use in areas such as arenas, stables, etc.
  - d. Dogs/pets running at large
  - e. Children unattended
  - f. Visitor/spectators in horse areas
  - g. Garbage disposal
  - h. Use of protective headgear, etc.
  - i. Any other areas of concern specific to the individual event that may exist. Identify them and have a plan to deal with them.

## **Biosecurity**

All show committees should follow general Equine Health and Welfare guidelines. Contact the SHF office for more information.

## **Accident/Untoward Incident Report Form**

1. Prepare a form and record any accident/incident that occurs at the event no matter how trivial it may seem at the time. The incident may involve any person or horse on the competition grounds. A sample form is included from the SHF for your consideration.
2. Have the report form signed, dated, and if possible signed by any relevant witnesses to the accident/incident. Make sure the report form answers the six big questions: WHO, WHAT, WHEN, WHERE, HOW, and WHY.

3. Describe the conditions present at the time, e.g. weather, crowds, outside interferences, etc. While such reports may seem unnecessary at the time, this record could be an invaluable aid should questions arise at a later date, especially in the event of any legal action.
4. A copy of the completed form should be forwarded to the SHF office with competition results.

**Remember: Legal action may be instituted up to two years or more following an incident. Therefore, it is essential to keep all records pertaining to the show, so that they can be accessed if needed at a later date.**

## **Protests & Complaints**

1. For protests regarding decisions of the competition official arising from the field of play (including decisions based on a factual observation of the performance during a competition or the awarding of marks for performance such as scores or placings):
  - a. The protest must be made in writing. It must be submitted, along with \$25.00 cheque payable to the Show Committee, within **one hour** of the statement of an alleged violation of a rule or condition of a class. In the case of an infraction involving another competitor, you must provide the name or competitor number of the alleged violator.
  - b. The Show Committee (and the competition official, if they so choose) will review the protest and determine a ruling based on the rules and regulations under which the show is sanctioned.
  - c. Once a final decision has been reached by the Show Committee there will be no further protest.
  - d. Protest fees will be returned only if the ruling is made in favour of the complainant. This procedure will take precedence over all other protest procedures.
2. For protests regarding an infraction to the SHF Code of Conduct:
  - a. This would fall under the SHF Discipline and Complaints Policy and should be referred to the SHF Office for the formal Dispute and Resolution process. For more details see [www.saskhorse.ca](http://www.saskhorse.ca) or contact the SHF Office.

# Officials

---

**Heritage Circuit** competition requires the use of SHF officials having a minimum of provincial primary status, Equestrian Canada officials, approved breed officials, or approved officials from other provinces.

**Heritage Circuit Dressage** competition requires the use of SHF officials having a minimum of provincial primary dressage status or Equestrian Canada dressage officials.

**Heritage Circuit Western Dressage** competition requires the use of WSDAC Judge status or judge Guest Carded through WSDAC.

A current list of officials is available through the SHF. Information on guest carding can be obtained by contacting the SHF office.

Before selecting your official(s) please consider the following conflict of interest situations:

1. Judges shall not officiate in any division in which a member of their family or a horse owned by the immediate family is competing, or in which clients and/or their horses are competing.
2. No judge who owns or is employed at an establishment may judge any horse or competitor that boards, is trained, or takes instruction at said establishment.
3. A judge may not judge any division where a competitor or exhibitor is the owner or employee of an establishment at which said judge boards, trains, or takes instruction.
4. Judges may not discuss the purchase, sale, or lease of any horse for the duration of a competition at which they are officiating.
5. Judges may not be the house guests of any person, or immediate family member of a person, who is competing in the event at which they are judging. This applies for a period from the day preceding to the completion of the event.
6. Neither Competition Managers nor members of their immediate families are eligible to serve in any position where they receive remuneration (such as judge, steward, course designer, or technical delegate) at any competition they are managing.

7. It is strongly recommended that Competition Managers, committee members, and members of their immediate families who compete at competitions they are managing, each declare a conflict of interest and should not be directly involved in paying officials. Declaration of conflict of interest forms are available at the SHF office.
8. Course Designers may not compete over any course which they have constructed or designed.
9. Ring Masters shall not officiate in any divisions of a competition in which they or any member of their immediate family or any of their clients are exhibitors.
10. No horse may be shown to a judge if that judge has owned, trained, or acted as an agent within the previous four months prior to the competition, excepting a judge that a competition has had to substitute due to circumstances beyond their control.
11. No horse may be shown to a judge that has been leased or owned by that judge within the four months prior to the start of the competition.

# **Saskatchewan Districts for Sport, Culture & Recreation**

---

## **Lakeland District for Sport, Culture and Recreation**

Prince Albert, Nipawin, Melfort

## **Northern Sport, Culture and Recreation District**

LaRonge, Cumberland House, Pelican Narrows, LaLoche, Stony Rapids

## **Parkland Valley Sport, Culture and Recreation District**

Yorkton, Melville, Esterhazy

## **Prairie Central District for Sport, Culture and Recreation**

Warman, Humboldt, Kelvington, Fort Qu'Appelle, Outlook

## **Regina District (No Office)**

City of Regina

## **Rivers West District for Sport, Culture and Recreation**

North Battleford, Lloydminster, Rosetown, Biggar, Kindersley, Meadow Lake

## **Saskatoon District (No Office)**

City of Saskatoon

## **South East Sport, Culture and Recreation District**

Weyburn, Estevan, Whitewood, Broadview

## **South West District for Culture, Recreation and Sport**

Moose Jaw, Swift Current, Assiniboia, Maple Creek

For a more detailed listing of communities in each District please visit [www.sasksport.sk.ca/districts.php](http://www.sasksport.sk.ca/districts.php)

# Heritage Circuit Divisions

Heritage recognized classes shall be assigned to one of **eight** divisions.

An Equitation division is offered with the points won qualifying for Equitation awards only.

1. Combining or splitting classes is at the discretion of the Show Organizing Committee. Examples:
  - a. The class offered may be an Open one, may be divided into Senior and Junior, or may have the Junior further broken down into the Junior age categories (A, B, C, or even A & B, C). In addition, each class may have ONE open class.
  - b. Classes may also be combined when entries are low. Junior ages may be combined to offer one Junior class; or Junior Combined B/C and Junior A; or Junior Combined A/B and Junior C. When classes are combined or split a rider will only earn points in their respective age category.
  - c. Competitions may also offer flat classes (Western Pleasure, English Pleasure, Road Hack and Show Hack) that are divided according to horse height. They shall be run as follows: Under 14.2hh, 14.2-15.2hh, Over 15.2hh.
  - d. Dressage classes may be judged as Junior, Senior and Open.
2. A competitor will earn Heritage Circuit points in their respective age category regardless of class combination or split.
3. A horse/rider combination will receive points from a maximum of three classes in any separate class event offered at a particular show, regardless of the number of classes they have placed in. The three top placings will count towards Heritage Circuit points.

## **Western Performance Division**

- Western Pleasure
- Trail
- Reining
- Western Riding

## **Ranch Division (2024 Pilot Project)**

- Working Western Rail
- Ranch Riding
- Ranch Trail

## **Hack Division**

- English Pleasure
- Road Hack
- Show Hack

## **Dressage Division**

- Introductory Level: EC Introductory Level Tests A, B, C
- Training Level: EC Training Level Tests 1, 2, 3, Freestyle
- First Level: EC First Level Tests 1, 2, 3, Freestyle

## **Speed Division**

- Barrel Race
- Pole Bending
- Key Hole Race
- Stake Race

## **Hunter Division**

- Cross rail Hunter
- 2'0" Hunter
- 2' 3" Hunter
- 2' 6" Hunter

## **Equitation Division**

- Showmanship at Halter
- Western Horsemanship
- English Equitation
- Hunt Seat Over Fences

## **Western Dressage Division**

- Introductory Level: WSDAC Introductory Level Tests A, B, C, D
- Basic Level: WSDAC Basic Level Tests A, B, C, D
- Level 1: WSDAC Level 1 Tests A, B, C, D
- Level 2: WSDAC Level 2 Tests A, B, C, D
- Level 3: WSDAC Level 3 Tests A, B, C, D

## **Additional Classes**

### **Junior Horse Classes**

Only horses 5 years and under may compete in Junior Horse classes.

- Junior Horse Western Pleasure
- Junior Horse English Pleasure

## **Pleasure Driving Classes**

- Turn out
- Working
- Reinsmanship

# **Heritage Awards**

---

Tentative - is subject to revision

## **District Division Champions and Reserve Champions**

Awarded to the Champion and Reserve horse/rider combination accumulating the most points in each division. For Dressage and Western Dressage, highest average score is used.

## **District High Point Champions**

Awarded to the Junior and Senior horse/rider combinations accumulating the most points in the English (Hack, Hunter and Dressage) and Western (Western Performance, Speed and Western Dressage) disciplines.

## **Provincial Class Champions**

Awarded to the Junior and Senior horse/rider combinations accumulating the most points in each class. For Dressage and Western Dressage, highest average score is used.

## **Provincial Division Champions and Reserve Champions**

Awarded to the Champion and Reserve, Junior and Senior horse/rider combination who demonstrate versatility by accumulating the most points in more than one class within the division (e.g. Trail and Reining). For Dressage and Western Dressage, highest average scores are used. Points/scores must be earned in a minimum of two classes.

## **Provincial High Point Champions and Reserve Champions**

Awarded to the Champion and Reserve, Junior and Senior horse/rider combinations accumulating the most points in the English (Hack, Hunter and Dressage) and Western (Western Performance, Speed and Western Dressage) disciplines.

## **Provincial Equitation Awards**

Awarded to the top three competitors in each age group in each of Showmanship, Horsemanship, English Equitation and Hunt Seat Over Fences. Points accumulated in Equitation do not count toward any other awards.

## **Junior Horse Champions**

Awarded to the top Junior horse(s) competing in English Pleasure Junior Horse and Western Pleasure Junior Horse classes. Points accumulated in Junior Horse classes do not count toward any other awards.

## **Pleasure Driving Champion**

Awarded to the top Pleasure Driving Horse/Driver combination competing in Turnout, Working and Reinsmanship. Points accumulated in Pleasure Driving classes do not count toward any other awards.

## **All-Around Champions**

Awarded to the Junior and Senior horse/rider combination accumulating the most points in all classes (except where noted with regards to the Equitation, Junior Horse and Pleasure Driving Awards). Points must be earned in a minimum of three Divisions.

## **Youth Sportsmanship Award**

Awarded to a Heritage nominated Junior competitor who exemplifies good sportsmanship at Heritage Circuit competitions.

## **Active for Life Award**

Presented annually to recognize a Heritage nominated competitor over 45 years of age (who has elected to be considered for this award). The winner will be determined by total points earned in competition.

## **Sask Bred High Point Awards**

This award recognizes the diversity of General Performance horses. Total points earned by all Sask Bred horses bred by a certain farm or person will be counted from the six Heritage Divisions. Annual recognition will be awarded to three top breeders of Heritage Circuit horses.

# Point Tabulation & Qualifying Rules

<b>Rule</b>	<b>Explanation</b>
<b>Minimum 'two show' rule</b>	To be considered for ANY Heritage award, a competitor must earn points at a minimum of two competitions.
<b>Minimum 'two class' rule</b>	To be considered for ANY Heritage award, a competitor must earn points in a minimum of two classes.
<b>Top six placings</b>	Only the top six class placings will be used to determine year end awards.
<b>Three classes per show</b>	A horse/rider combination will receive points from a maximum of three classes in any separate class event offered at a particular show, regardless of the number of classes they have placed in. Top three placings will count toward Heritage Circuit points.
<b>Maximum classes allowed rule</b>	Where rules stipulate that a maximum number of classes per day are allowed (i.e., Hunter maximum 4 over fence classes and Dressage/Western Dressage maximum 4 tests), a competitor who has results submitted in excess of the allowed number will have only their first allowable scores count toward awards and will forfeit any points earned after the limit was exceeded.
<b>Maximum consecutive class rule</b>	Where rules stipulate a maximum number of consecutive heights or levels (i.e., Hunter 3 consecutive heights and Dressage/Western Dressage 2 consecutive levels) a competitor who has results submitted in excess of the allowed limit, will have only their first scores or points count, and subsequent scores forfeited.
<b>Minimum Dressage score</b>	To be declared a Provincial Dressage Champion/Reserve Champion a horse/rider must score a minimum of 60/57%.

<b>Rule</b>	<b>Explanation</b>
<b>Age of rider</b>	A competitor's age will be determined by the year listed on their birth certificate. A competitor must ride in their age group where classes are split by age.
<b>Combining or splitting classes</b>	A competitor will earn points in their respective age category regardless of class split.

1. A horse and rider must be nominated to the Heritage Circuit to be eligible for awards. The rider must be a current, individual member of the SHF. **Horse/rider pairs nominated for the Heritage Circuit will begin point accumulation only AFTER the horse/rider combination is nominated.** Points earned prior to nomination of horse/rider WILL NOT be considered.
2. For all Heritage awards, each horse/rider pair will have points from their top six placings used to determine awards. Points will be earned as per the following table:

	<b>5 or more Horses in Class</b>	<b>4 Horses in Class</b>	<b>3 Horses in Class</b>	<b>2 Horses in Class</b>	<b>1 Horse in Class</b>
<b>1st</b>	5 points	4 points	3 points	2 points	1 point
<b>2nd</b>	4 points	3 points	2 points	1 point	--
<b>3rd</b>	3 points	2 points	1 point	--	--
<b>4th</b>	2 points	1 point	--	--	--
<b>5th</b>	1 point	--	--	--	--

3. A horse may be nominated by more than one person, but points and awards will be given **per nominated horse/rider combination** for awards. To earn points with a second rider, the horse/rider pair must file and pay for a second nomination in that rider's name. Points are non-transferable.
4. A horse must be entered in a show using the name submitted on the nomination form, spelled correctly to ensure proper computer entry.
5. Eligible classes for points and awards from each division will be published each year.
6. A nominated individual's points will not be released without the written permission from the nominated rider/handler. After all

points are tabulated and awards designated, the points will be official and available to nominated members.

7. Equitation and Showmanship points may be won using any nominated horse, but an individual may not accumulate points from more than one entry in any eligible class at a particular show. Rider/handler judged classes such as Showmanship and Equitation shall have their own division with their own awards. **These points will not count toward other awards.**
8. **District Division Champions and Reserve Champions** will be awarded to the horse/rider combination accumulating the most points in each division. Points must be earned in more than one class within the division (ie. Trail and Reining). For Dressage and Western Dressage, highest average score is used.
9. **District High Point Champions** will be awarded to the Junior and Senior horse/rider combination accumulating the most points in the English (Hack, Hunter and Dressage) and Western (Western Performance, Speed and Western Dressage) disciplines. Points must be earned in more than one division. District High Point awards are awarded in the district in which the rider lives, but points may be earned at any Heritage Circuit show.
10. **Provincial Class Champions** are awarded for each recognized Heritage class. Top Junior and Senior riders who have accumulated the most points in each class designation (e.g. Western Pleasure) will be declared winners. For Dressage and Western Dressage, highest average score is used.
11. **Provincial Division Champions and Reserve Champions** titles are awarded for each Heritage division. This award rewards horse/rider combinations that demonstrate versatility by accumulating the most points in more than one class type within the Division (e.g. Trail and Reining). For Dressage and Western Dressage, highest average scores are used. To be declared a Division Champion, points must be earned in a minimum of two class designations. See #15-c for Dressage & Western Dressage scoring and #16-c for Hunter scoring.
12. **Provincial High Point Champions and Reserve Champions** is awarded to the Champion and Reserve, Junior and Senior rider accumulating the most points in the English (Hack, Hunter and Dressage) and Western (Western Performance, Speed and Western Dressage) disciplines. Points must be earned in more than one division.

- 13. Provincial Equitation Awards** (Horsemanship, Showmanship, English Equitation on the Flat and Hunt Seat Over Fences). Points may be earned using more than one horse, providing all horses are nominated under that rider's name. An individual may not accumulate points from more than one entry in any eligible class at a show. Points earned in Equitation do not count toward any other award.
- 14. All-Around Champions** titles are awarded to one top Junior and one top Senior rider who have accumulated the most points throughout the competition year. Riders eligible for this award must have earned points in a minimum of three divisions.
- 15. Dressage/Western Dressage Scoring:**
- a. The Heritage Circuit recognizes that the classes within the Dressage Divisions are based on 'degree of difficulty' rather than being distinctly different types of classes, as in other divisions.
  - b. To determine Dressage Champions, the top six scores will be averaged and will have the following coefficients applied: Introductory Level (x1), Training Level/Basic Level (x1.1), and First Level/Level 1-3 (x1.2). The horse/rider combination with the highest average score will be declared the champion.
  - c. Scores can be earned at any level.
  - d. Regular Dressage points for placings will be used to determine High Point and All-Around Champions.
  - e. **Provincial Dressage Class Champions** must earn a minimum average score of 60%. **Provincial Dressage Division Champions** must earn a minimum average score of 60% for Champions and 57% for Reserve Champions.

## 16. Hunter Scoring:

- a. The Heritage Circuit recognizes that the classes within the Hunter Division are based on 'degree of difficulty' rather than being distinctly different types of classes, as in other divisions.
- b. To Determine Hunter Champions a competitor's top six placings will have the following coefficients applied: Cross rail (x1), 2' (x1.2), 2'3 (x1.4), 2'6 (x1.6). The horse/rider combination accumulating the most points will be declared champion.
- c. Points may be earned at any height.
- d. Hunter Under Saddle classes do not count toward Heritage awards but may be part of Hunter Division Championships offered by a competition.
- e. Regular Hunter points for placings will be used to determine High Point and All-Around Champions.

# Rules of Competition

1. **SHF Helmet Policy: All youth under the age of 18 as determined by their year of birth as it appears on their birth certificate will be required to wear an approved ASTM/SEI helmet when participating in any event sanctioned by the Saskatchewan Horse Federation. This is for safety and insurance purposes.**
  - a. Exemption allowed: Upon request, a competition may be granted an exemption to this rule if it is sanctioned under an approved set of Breed, International or National Rules and regulations. **HOWEVER, Heritage and Prairie Cup approved classes running within the same competition must follow the SHF Helmet Policy whereby all juniors will wear properly fitted and fastened approved headgear at all times while riding or driving at the event location. It is understood that juniors not meeting this requirement will not be allowed to compete in the Heritage or Prairie Cup classes at these competitions.**
  - b. **All Junior and Senior riders in English Dressage, regardless of the level they are competing at, must wear an approved helmet.**
  - c. **All Junior Western Dressage riders, regardless of the level they are competing at, must wear an approved helmet. Senior Western Dressage riders may wear a western hat or an approved helmet.**
  - d. **The SHF Helmet Policy is in effect while mounted anywhere on the competition grounds (including warm-up arenas).**
2. In Showmanship an exhibitor may be in either Western or English attire. Junior participants must wear a helmet.
3. Mannerly stallions may be shown by Senior exhibitors ONLY.
4. **Riders must compete in their Age Division, or Open Classes if they choose, as determined by the Year of Birth as it appears on their Birth Certificate**

Age Division	Year of Birth
Junior C	2012 or later
Junior B	2009 to 2011
Junior A	2006 to 2008
Senior	2005 or earlier

5. Exhibitors may ride more than one horse in classes requiring only individual work, regardless of age, up to a maximum of three entries. However, a horse can only compete once in a specific age category class and an Open class at a show within a division. For example: A horse can be entered in Senior Western Pleasure and Open Western Pleasure but could NOT be ridden by a different rider in any Junior Western Pleasure class. If there is elimination, each horse must be ridden in the actual class by the same rider who rode it in the elimination.
6. In any class or event requiring equipment such as Trail Class, Pole Bending, etc., competitors MUST NOT use the show's equipment for practicing before the class or event begins, on penalty of disqualification.
7. The management of any contest shall determine whether or not elimination is necessary, the number of go-rounds to be held, and the number of horses to be shown at each performance.
8. The final placing of each horse is to be determined by totaling its scores in the finals plus elimination and/or go-rounds.
9. In all classes, any rider and/or horse which falls during the performance is automatically disqualified. A rider has fallen when he/she has to vault or mount in the ring. A horse has fallen when both the shoulder and haunch touch the ground.
10. In all performance classes that are judged on the rail, horses are to reverse to the inside (away from the rail). They may be required to reverse at the walk or jog at the discretion of the judge but shall not be asked to reverse at the lope.
11. Competition rings, arenas, and warm up areas should be fenced and should have a safe gate or door that will open and shut. All speed events must be run in an enclosed arena with no open gates. Show Committees are responsible for ensuring safe footing for all classes. Failure to comply with the above may result in loss of insurance coverage.
12. Obvious sideline coaching or obvious ringside assistance while rider is being judged may result in the disqualification of the exhibitor.
13. **Discipline:** Exhibitors are warned that any act of discourtesy or disobedience to the officials on the part of the owner, groom, rider, driver, or member of the family participating in the show, will disqualify the horse and exhibitor. The management of the show has the right to remove a groom, horse, rider or driver from the show without being liable for compensation or damages.

## English Attire

1. In all English classes competitors and judges should bear in mind that entries are being judged on ability rather than personal attire.
2. Riders should wear hunt coats of traditional hunt style and conservative color, breeches of traditional shades, and traditional high black or brown English boots should be worn but paddock boots (black or brown) may be used with matching smooth leather half chaps (no Suede).
3. A black, navy or brown approved helmet with a permanently affixed harness is compulsory.
4. A tie, choker, or stock is required.
5. Hair must be neat and contained as in a net or braid.
6. For English Pleasure and Equitation, Saddle Seat attire is allowed.

## English Tack

1. In all English classes a snaffle, pelham, kimberwick, or full bridle with plain leather cavesson nose bands and brow bands must be used. Colored cavesson and brow bands may only be used in English Pleasure classes.
2. An English saddle in black or brown with a proper English saddle pad should be used.
3. No whips are allowed in English Pleasure or Hack classes.
4. Optional equipment:
  - a. Spurs
  - b. Gloves
  - c. Whip (not allowed in English Pleasure or Hack classes)
  - d. Braiding of mane and tail
  - e. Standing or running martingales (ONLY in Hunter over fences classes)
  - f. Boots/Leg protection (in Hunter classes at Judge's discretion ONLY)

## Western Attire

1. Senior competitors may wear protective headgear in any division or class without penalty from the judge. Junior competitors must wear a safety approved helmet. The hat or helmet must be on the rider's head when the exhibitor enters the arena.
2. Exhibitors must wear appropriate Western attire, including a shirt with long sleeves and collar, Western hat or approved helmet, Western pant with belt, and cowboy boots.
3. Spurs, chaps, and gloves are optional.

## Western Tack

1. In all Western classes, horses will be shown in a Western stock saddle. Australian stock saddles are not permitted.
2. A Western bridle with a Western curb bit shall be used on senior horses. On senior horses the reins may only be held in one hand. The reins may be split or of the romal type. The index finger is only allowed between split reins but not with romal reins. When using a romal rein the braided extension is allowed to be carried in the free hand with 16 inches spacing between the free hand and the reining hand.
3. Silver equipment will not count over a good working outfit.
4. Junior horses, five years and under may be shown in a snaffle bit or bosal with two hands on the reins.
5. Curb chain or curb strap are required on curb bits and must be at least one-half inch in width and lie flat against the jaw of the horse. A curb strap is to be used on a snaffle bit and must be at least one-half inch in width.
6. Optional equipment:
  - a. Rope or riata attached to the saddle
  - b. Hobbles attached to the saddle
  - c. Breast collars
  - d. Protective boots or leg wraps and bandages are allowed in reining, speed events and horsemanship
  - e. Martingales, nosebands, and tie downs are allowed ONLY in speed events
7. References to hackamore mean the use of a flexible, braided rawhide or leather, or rope bosal, the core of which must be rawhide. Absolutely no rigid material will be allowed under the jaws, regard-

less of how padded or covered. Horsehair bosals are prohibited. A “mechanical” hackamore may only be used in speed events.

8. References to snaffle bits in Western Performance classes are to the conventional O-ring, egg-butt or D-ring with a ring no bigger than 4” (100 mm). The inside circumference of the ring must be free of rein, curb or headstall attachments which would provide leverage. The mouthpiece should be round, oval or egg-shaped, smooth and unwrapped metal. It may be inlaid, but smooth or latex-wrapped. The bars must be a minimum of 5/16” (8 mm) in diameter, measured 1” (25 mm) in from the cheek with a gradual decrease to center of the snaffle. The mouthpiece may be two or three pieces. A three- piece, connecting ring of 1” to 1-1/4” (25 mm to 32 mm) or less in diameter, or a connecting ring of 1-1/4” (32 mm) or less in diameter, or a connecting flat bar of 3/8” to 3/4” (10 mm to 20 mm) measured top to bottom, with a maximum length of 2” (50 mm), which lies flat in the horse’s mouth is acceptable.
9. References to a bit in Western Performance classes mean the use of a curb bit that has a solid or broken mouthpiece, has shanks and acts as leverage. All curb bits must be free of mechanical device and should be considered a standard Western bit. A description of a legal, standard Western bit includes:
  - a. 8-1/2” (215 mm) maximum length shank to be measured as indicated in the diagram at the end of this article/ Shanks may be fixed or loose.
  - b. Concerning mouthpieces, bars must be round, oval or egg shaped, smooth and unwrapped metal of 5/16” to 3/4” (8 mm to 20 mm) in diameter, measured 1” (25 mm) from the cheek. They may be inlaid but must be smooth or latex wrapped. Nothing may extend below the mouthpiece (bar), such as extensions or prongs on solid mouthpieces. The mouthpiece may be two or three pieces. A three-piece, connecting ring of 1-1/4” (32 mm) measured top to bottom with a maximum length of 2” (50 mm) which lies flat in the horse’s mouth is acceptable.
  - c. The port must be no higher than 3-1/2” (90 mm) maximum, with rollers and covers acceptable. Broken mouthpieces, half-breeds and spades are standard.
  - d. Slip or gag bits, and donut and flat polo mouthpieces are not permitted.

## Acceptable Chain Curb Straps

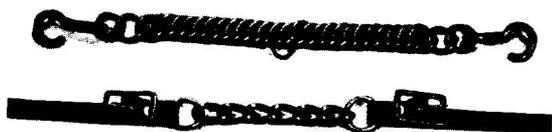

## Legal Bit

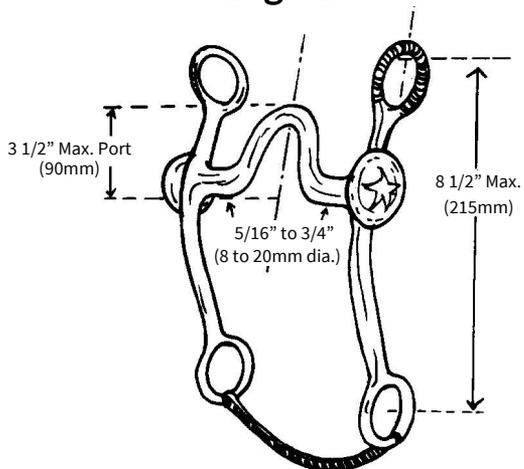

## Illegal Bits

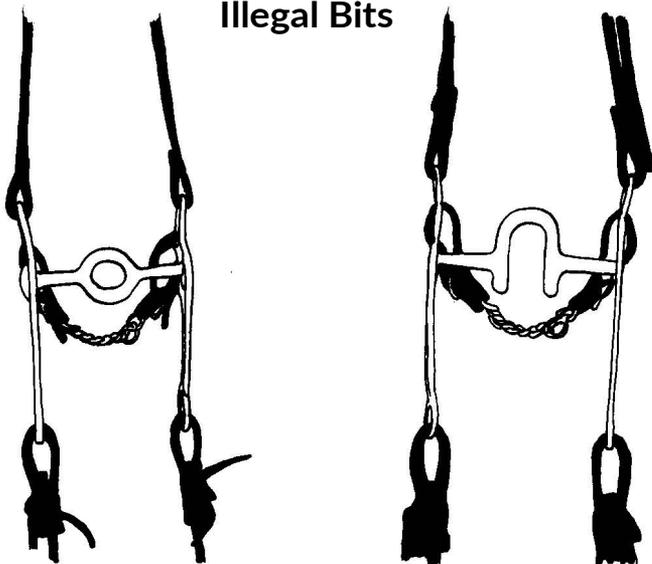

Donut Bit

Prong Bit

# Western Performance Division

## Terminology

The following terminology shall apply in Western Performance Division classes whenever a specific gait is called for:

1. The **walk** is a natural, flat footed, **four-beat** gait. The horse must move straight and true at the walk. The walk must be alert, with a stride of reasonable length in keeping with the size of the horse.
2. The **jog** is a smooth, ground covering **two-beat** diagonal gait. The horse works from one pair of diagonals to the other pair. The jog should be square, balanced and with straight forward movement of the feet. Horses walking with their back feet and trotting on the front are not considered performing the required gait. When asked to extend the jog, the horse moves out with the same smooth way of going.
3. The **lope** is an easy, rhythmical **three-beat gait**. Horses moving to the left should lope on the left lead. Horses moving to the right should lope on the right lead. Horses traveling at a four-beat gait are not considered to be performing at the proper lope. The horse should lope with a natural stride and appear relaxed and smooth. The horse should be ridden at a speed which is in keeping with his natural way of going.

# Western Pleasure

---

## General

A good pleasure horse has a free-flowing stride of reasonable length in keeping with its conformation. It should cover a reasonable amount of ground with little effort. Ideally, it should have a balanced, flowing motion while exhibiting correct gaits that are of proper cadence. The quality of the movement and the consistency of the gaits is a major consideration. It should carry its head and neck in a relaxed natural position, with its poll level with or slightly above the level of its withers. It should not carry its head behind the vertical, giving the appearance of intimidation or be excessively nosed out, giving a resistant appearance. Its head should be level, with its nose slightly in front of vertical having a bright expression with its ears alert. It should be shown on a reasonably loose rein, but with light contact and control. It should be responsive, yet smooth, in transitions when called for. When asked to extend, it should move out with the same flowing motion. Maximum credit should be given to the flowing, balanced and willing horse that gives the appearance of being fit and a pleasure to ride.

## Class Conduct

1. This class will be judged on performance, condition and conformation of the horse; however, a minimum of 20% of the judging shall be placed on condition and conformation.
2. Horses must work both ways of the ring at all three gaits to demonstrate their ability with different leads. At the option of the judge, horses may be asked to extend the walk, jog, or lope, one or both ways of the ring. The judge may ask all or just the top 12 horses to extend at the jog, however, not more than the top 12 horses may be asked to extend at the lope. The rider should sit at the extended jog.
3. Horses are required to back easily and stand quietly.
4. Horses are to be reversed to the inside (away from the rail). They may be required to reverse at the walk or the jog at the discretion of the judge but shall not be asked to reverse at the lope.

# Reining

---

## General

To rein a horse is not only to guide it, but also to control its every movement. The best reined horse should be willfully guided or controlled with little or no apparent resistance and dictated to completely.

1. Desired qualities possessed by a good reining horse are smoothness, finesse, attitude, quickness and authority in performing the various reining maneuvers.
2. The rider controls every movement of the horse as he guides it throughout the pattern.
3. Correct maneuvers are essential to the reining horse's performance and when controlled are the basis for speed.
4. When ridden at speed the horse should perform willingly with no evidence of resistance to the rider's aids.
5. Rundowns should be controlled and fluid.
6. The stop should demonstrate proper frame, balance and style.
7. The form of the horse in the slide supersedes the actual distance traveled.
8. To qualify as a roll back, timing and balance between horse and rider must be in near-perfect harmony through the stop, turn and lope departure.
9. Lead changes must be made with precision and balance.

## Class Conduct

1. Each contestant will perform the required pattern individually and separately. All horses will be judged immediately upon entering the arena, and judging will cease after the last maneuver. Any fault incurred prior to the commencement of a pattern will be scored accordingly.
2. To rein a horse is not only to guide him, but also to control his every movement.
  - a. The best reined horse should be willingly guided or controlled with little or no apparent resistance and dictated to completely.
  - b. Any movement on his own must be considered a lack of control.
  - c. All deviations from the exact written pattern must be considered a lack of or temporary loss of control, and therefore faulted according to severity of deviation.

- d. Credit will be given for smoothness, finesse, attitude, quickness and authority in performing the various maneuvers while using controlled speed.
  - e. Excess rein may be straightened while in motion, provided the free hand remains behind the rein hand.
3. All riders must drop the bridle immediately after the performance. The bridle must be checked by the designated judge in the arena or in a close proximity to the arena.

## Scoring

Scoring will be on the basis of 0–Infinity, with 70 denoting an average performance. Neither a no score nor a zero (0) score can place.

## Penalties

### No Score:

- Infraction of any provincial or federal law
- Abuse of an animal in the show arena and/or evidence that abuse has occurred prior to or during the exhibition of a horse (blood on sides/mouth)
- Use of illegal equipment
- Use of illegal bits, bosals or curb straps
- Use of tack collars, tie downs or nosebands
- Use of whips
- Use of any attachment that alters the movement or circulation of the tail
- Failure to dismount and present horse and tack to appropriate judge
- Disrespect or misconduct by the exhibitor. The Judge may excuse any horse at any time while in the arena for unsafe conditions or improper exhibition pertaining to both the horse and/or the rider.
- Closed reins are not allowed except as standard romal reins.

### Zero (0) Score:

- Use of more than the index or first finger between reins
- Use of 2 hands (except snaffle bit or hackamore classes) or changing hands
- Use of romal except as outlined in the rules
- Failure to complete pattern as outlined
- Performing maneuvers out of order
- Inclusion of maneuvers not specified, including but not limited to:

- Backing more than 2 strides
- Turning more than 90 degrees
- Exception: A complete stop in the 1st quarter of a circle after a lope departure is not to be considered an inclusion of a maneuver, a 2-point break of gait penalty will apply.
- Equipment failure
- Balking or refusal of command where the pattern is delayed
- Running away or failing to guide where it becomes impossible to discern if the entry is on pattern
- Jogging in excess of ½ circle or ½ the length of the arena
- Over spins of more than ¼ turn
- When going to or coming out of a rollback in a pattern requiring a run around, a rollback that crosses the center line
- Fall to the ground by horse or rider
- Dropping a rein that contacts the ground while the horse is in motion
- Failure to have the correct number displayed
- Failure to wear correct western attire

### **Five (5) Point Penalty:**

- Spurring in front of the cinch
- Use of either hand to install fear or praise
- Holding saddle with either hand
- Blatant disobedience including kicking, rearing, biting, bucking or striking

### **Two (2) Point Penalty:**

- Break of gait
- Freezing up in spins or rollbacks
- On walk in patterns, loping prior to reaching the center and/or failure to stop or walk before executing a lope departure
- On run in patterns, failure to be in a lope prior to reaching the first marker
- If a horse does not completely pass the specified marker before initiating a stop position
- Jogging beyond 2 strides but less than ½ circle or ½ length of the arena
- For run-around patterns, failure to be on the correct lead when rounding the end of the arena will be penalized for more than half of the turn

## One (1) Point Penalty:

- Each time a horse is out of lead
- Penalty for being out of lead on a circle is accumulative, and a judge will add a 1 point penalty for each  $\frac{1}{4}$  circle or any part thereof that the horse is out of lead.
- Over or under spinning up to  $\frac{1}{4}$  turn
- For run-around patterns, failure to be on the correct lead for half of the turn or less when rounding the end of the arena

## Half ( $\frac{1}{2}$ ) Point Penalty:

- A judge is required to penalize a horse  $\frac{1}{2}$  point for a delayed change of lead by one stride where the lead change is required by the pattern description.
- Starting a circle at a jog
- Exiting a rollback at a jog up to 2 strides
- Over or under spinning up to  $\frac{1}{8}$  of a turn
- Failure to stay 20 feet from the wall when approaching a stop or rollback.

**If there is any doubt regarding a penalty, credit goes to the exhibitor.**

## Maneuvers

-1½	Extremely Poor
-1	Very Poor
-1/2	Poor
0	Average/Correct
+1/2	Good
+1	Very Good
+1½	Excellent

## Hierarchy of Concern

1. On Pattern
2. Correctness
3. Level of Difficulty

# The Work

## Credit

- Authority of Execution
- Smoothness
- Finesse
- Quickness
- Speed Control

## Discredit

- Lack of Control
- Resistance

## Faults

1. Faults against the horse to be scored accordingly, but not to cause disqualification:
  - Opening mouth excessively when wearing bit
  - Excessive jawing, opening mouth or head raising on stop
  - Lack of smooth, straight stop on haunches-bouncing or sideways stop
  - Refusing to change leads
  - Anticipating signals
  - Stumbling
  - Backing sideways
  - Knocking over markers
2. Faults against the rider to be scored accordingly, but not to cause disqualification:
  - Losing a stirrup
  - Failure to run circles or figure eights within the markers is not considered a fault depending on arena conditions and size.
  - While horse is in motion, rider's hands shall be clear of horse and saddle.

## Other

1. A show may have up to three approved reining classes.
2. If three reining classes are to be held at a show, they shall be the following:
  - a. Senior rider reining
  - b. Junior rider reining
  - c. Open reining
3. If two reining classes are to be held at a show, they shall be the following:
  - a. Senior rider reining
  - b. Junior rider reining

4. If only one reining class is to be held at a show, it shall be the following:
  - a. Reining—all ages, horses 6 years old and older must be shown in bit, horses 5 years old and younger may be shown in either bit, hackamore or snaffle bit at the discretion of the exhibitor.
5. **Reining Arena Setup:** Markers are to be placed on the wall or fence of the arena as follows:
  - a. At the center of the arena
  - b. At least 50 ft from each end wall
6. All patterns are to be worked as stated, not as drawn.
7. Where the pattern designates stops to be beyond a marker, the horse should begin his stop after he passes the specified marker.
8. Each pattern is drawn so the bottom of the page represents the end of the arena entered by the contestants and must be run as such. In the event an arena has only one gate and it is in the exact middle of the side, that side will represent the right side of the pattern as drawn.
9. All horses will be judged immediately upon entering the arena and judging will cease after the last maneuvers. Any fault incurred prior to the commencement of a pattern will be scored accordingly. Judges' decisions are final.

# Heritage Reining Pattern 1

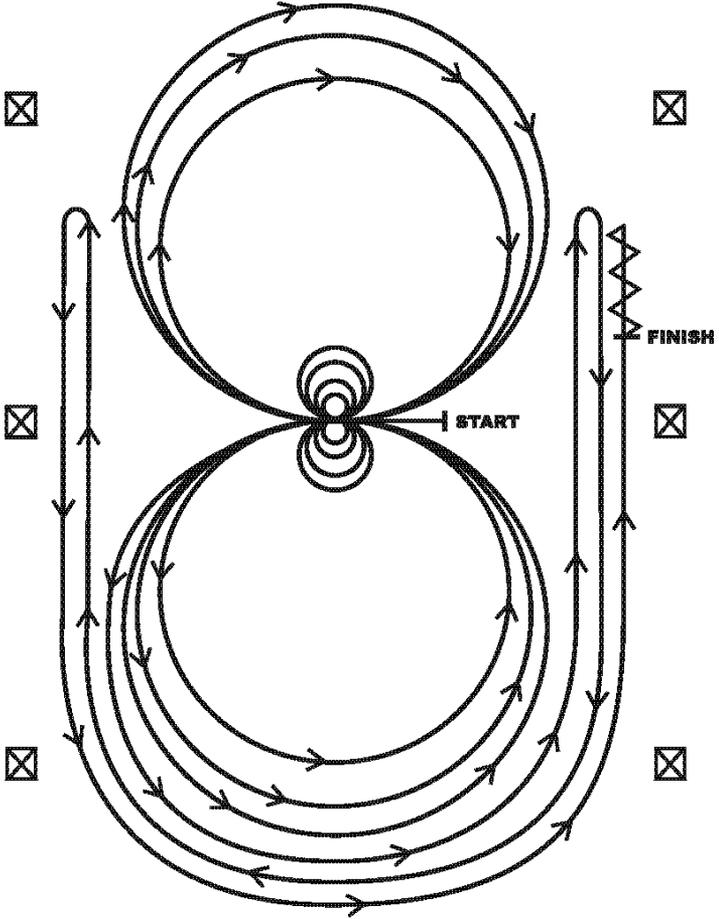

# Heritage Reining Pattern 1

Horses may walk or trot to the center of arena. Horses must walk or stop prior to starting pattern. Beginning at the center of the arena facing the left wall or fence.

1. Complete four spins to the right. Hesitate.
2. Complete four spins to the left. Hesitate.
3. Beginning on the left lead, complete three circles to the left: the first two circles large and fast; the third circle small and slow. Change leads at the center of the arena.
4. Complete three circles to the right: the first two circles large and fast; the third circle small and slow. Change leads at the center of the arena.
5. Begin a large fast circle to the left but do not close this circle. Run up the right side of the arena past the center marker and do a right rollback at least twenty feet (six meters) from the wall or fence – no hesitation.
6. Continue back around previous circle but do not close this circle. Run up the left side of the arena past the center marker and do a left rollback at least twenty feet (six meters) from the wall or fence – no hesitation.
7. Continue back around previous circle but do not close this circle. Run up the right side of the arena past the center marker and do a sliding stop at least twenty feet (six meters) from the wall or fence. Back up at least ten feet (three meters). Hesitate to demonstrate the completion of the pattern.

Rider must dismount and drop bridle to the designated judge.

# Heritage Reining Pattern 2

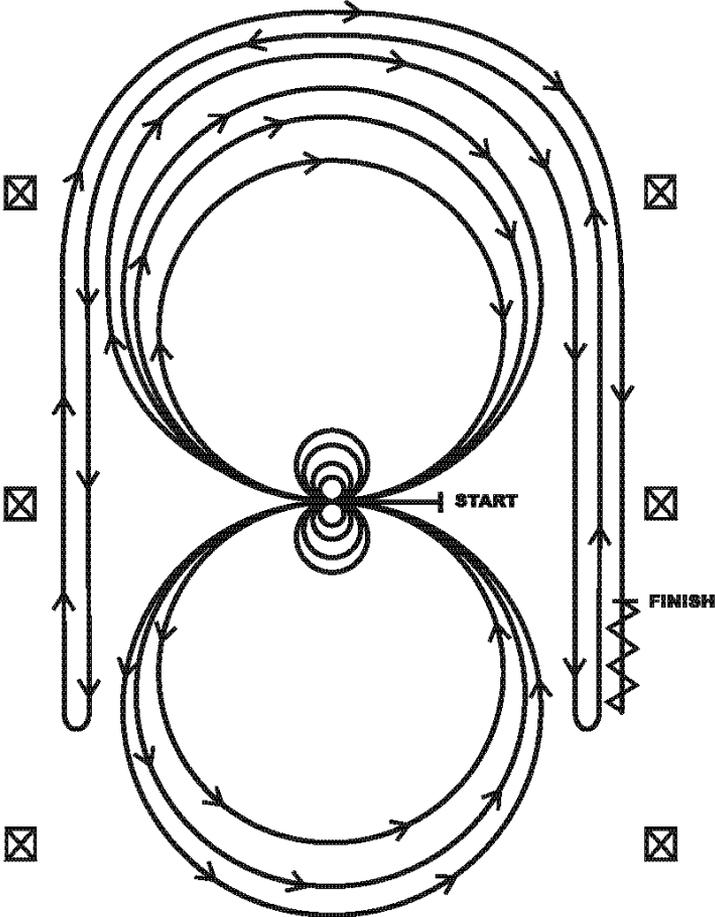

## Heritage Reining Pattern 2

Horses may walk or trot to the center of arena. Horses must walk or stop prior to starting pattern. Beginning at the center of arena facing the left wall or fence.

1. Complete four spins to the left. Hesitate.
2. Complete four spins to the right. Hesitate.
3. Beginning on the right lead, complete three circles to the right: the first circle large and fast; the second circle small and slow; the third circle large and fast. Change leads at the center of the arena.
4. Complete three circles to the left: the first circle large and fast; the second circle small and slow; the third circle large and fast. Change leads at the center of the arena.
5. Begin a large fast circle to the right but do not close this circle. Run straight down the right side of the arena past the center marker and do a left roll-back at least twenty feet (six meters) from the wall or fence – no hesitation.
6. Continue back around the previous circle but do not close this circle. Run down the left side of the arena past the center marker and do a right rollback at least twenty feet (six meters) from the wall or fence – no hesitation.
7. Continue back around the previous circle but do not close this circle. Run down the right side of the arena past the center marker and do a sliding stop at least twenty feet (six meters) from the wall or fence. Back up at least ten feet (three meters). Hesitate to demonstrate completion of the pattern.

Rider must dismount and drop bridle to the designated judge.

# Heritage Reining Pattern 3

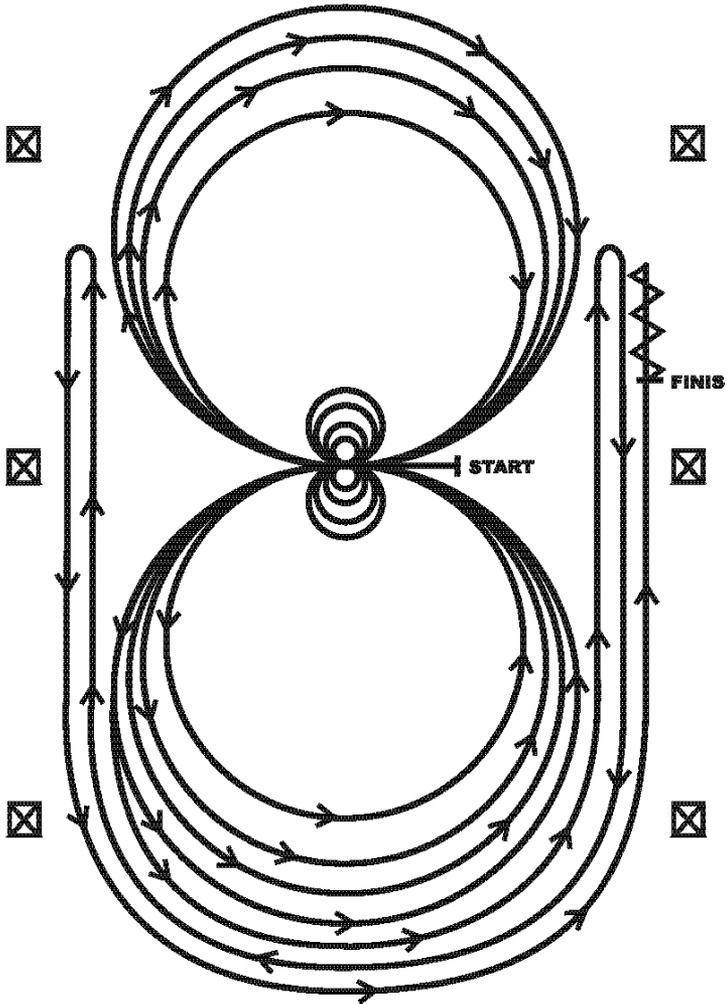

## Heritage Reining Pattern 3

Horses may walk or jog to the center of arena. Horses must walk or stop prior to starting pattern. Beginning at the center of the arena facing the left wall or fence.

1. Beginning on the left lead, complete three circles to the left: the first two circles large and fast; the third circle small and slow. Stop at the center of the arena. Hesitate.
2. Complete four spins to the left. Hesitate.
3. Beginning on the right lead, complete three circles to the right: the first two circles large and fast; the third circle small and slow. Stop at the center of the arena. Hesitate.
4. Complete four spins to the right. Hesitate.
5. Beginning on the left lead, run a large fast circle to the left, change leads at the center of the arena, run a large fast circle to the right, and change leads at the center of the arena. (Figure 8)
6. Continue around previous circle to the left but do not close this circle. Run up the right side of the arena past the center marker and do a right rollback at least twenty feet (six meters) from the wall or fence—no hesitation.
7. Continue around previous circle but do not close this circle. Run up the left side of the arena past the center marker and do a left rollback at least twenty feet (six meters) from the wall or fence—no hesitation.
8. Continue back around previous circle but do not close this circle. Run up the right side of the arena past the center marker and do a sliding stop at least twenty feet (six meters) from the wall or fence. Back up at least ten feet (three meters). Hesitate to demonstrate completion of the pattern.

Rider must dismount and drop bridle to the designated judge.

# Heritage Reining Pattern 4

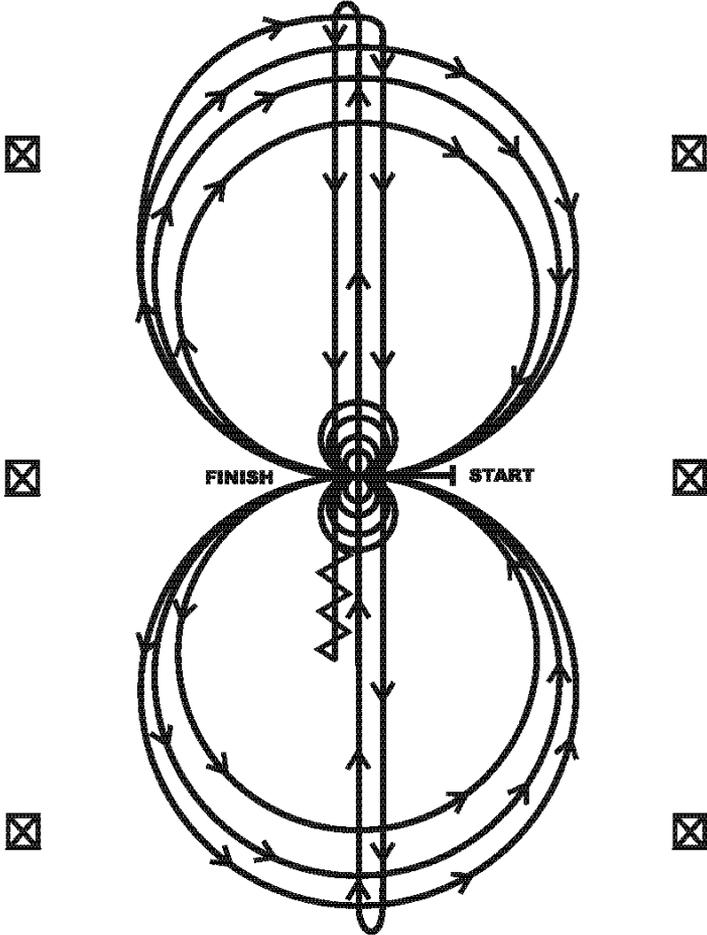

# Heritage Reining Pattern 4

Horses may walk or jog to the center of arena. Horses must walk or stop prior to starting pattern. Beginning at the center of the arena facing the left wall or fence.

1. Beginning on the right lead, complete three circles to the right: the first circle small and slow; the next two circles large and fast. Change leads at the center of the arena.
2. Complete three circles to the left: the first circle small and slow; the next two circles large and fast. Change leads at the center of the arena.
3. Continue around previous circle to the right. At the top of the circle, run down the middle to the far end of the arena past the end marker and do a right rollback—no hesitation.
4. Run up the middle to the opposite end of the arena past the end marker and do a left rollback—no hesitation.
5. Run past the center marker and do a sliding stop. Back up to the center of the arena or at least ten feet (three meters). Hesitate.
6. Complete four spins to the right. Hesitate.
7. Complete four spins to the left. Hesitate to demonstrate the completion of the pattern.

Rider must dismount and drop bridle to the designated judge.

# Heritage Reining Pattern 5

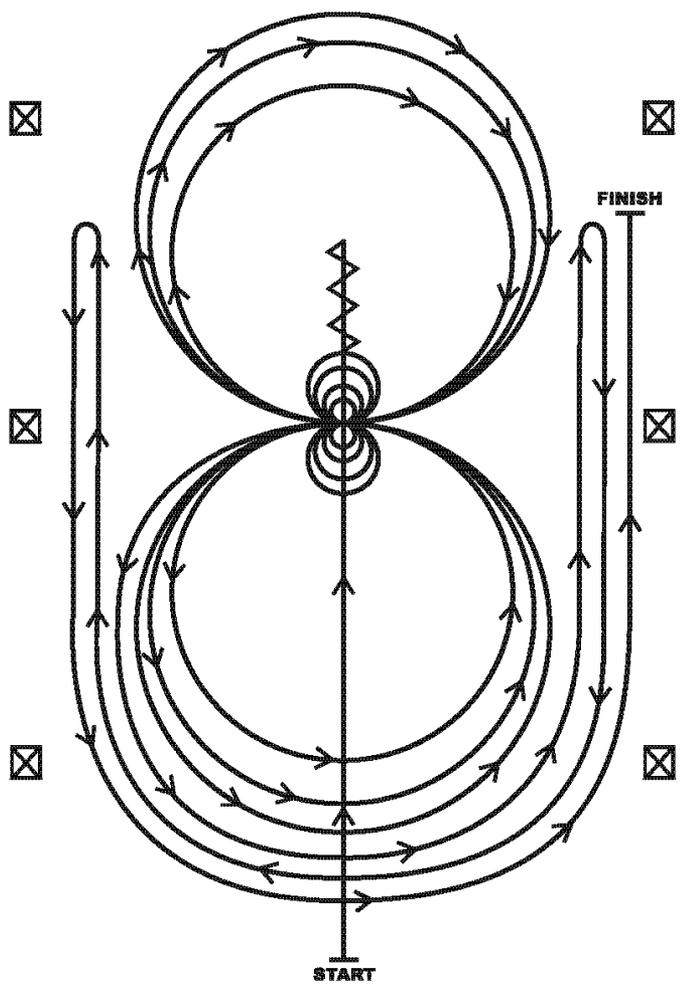

## Heritage Reining Pattern 5

1. Run past the center marker and do a sliding stop. Back up to the center of the arena or at least ten feet (three meters). Hesitate.
2. Complete four spins to the right. Hesitate.
3. Complete four and one-quarter spins to the left so that horse is facing the left wall or fence. Hesitate.
4. Beginning on the left lead, complete three circles to the left: the first circle small and slow; the next two circles large and fast. Change leads at the center of the arena.
5. Complete three circles to the right: the first circle small and slow; the next two circles large and fast. Change leads at the center of the arena.
6. Begin a large circle to the left but do not close this circle. Run up the right side of the arena past the center marker and do a right rollback at least twenty feet (six meters) from the wall or fence—no hesitation.
7. Continue back around the previous circle but do not close this circle. Run up the left side of the arena past the center marker and do a left rollback at least twenty feet (six meters) from the wall or fence—no hesitation.
8. Continue back around previous circle but do not close this circle. Run up right side of the arena past the center marker and do a sliding stop at least twenty feet (six meters) from the wall or fence. Hesitate to demonstrate completion of the pattern.

Rider must dismount and drop the bridle to the designated judge.

# Heritage Reining Pattern 6

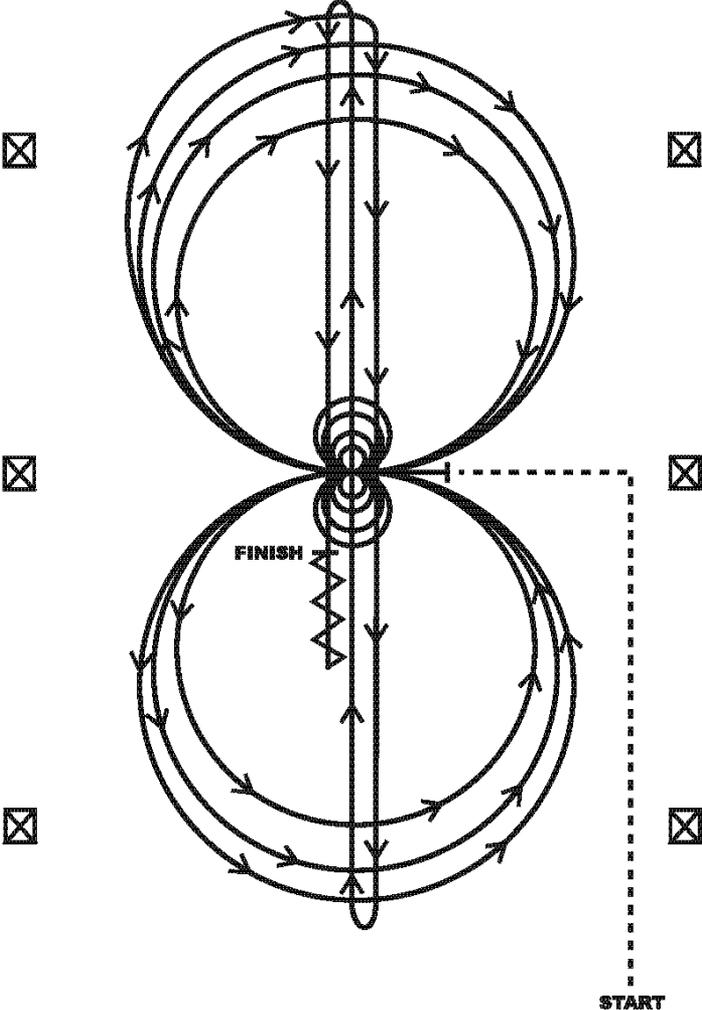

# Heritage Reining Pattern 6

Horses must jog to the center of the arena. Horses must walk or stop prior to starting the pattern. Beginning at the center of the arena facing the left wall or fence.

1. Complete four spins to the left. Hesitate.
2. Complete four spins to the right. Hesitate.
3. Beginning on the right lead complete three circles to the right; the first circle small and slow; the next two circles large and fast. Change leads at the center of the arena.
4. Complete three circles to the left; the first circle small and slow; the next two circles large and fast. Change leads at the center of the arena.
5. Begin a large circle to the right, but do not close this circle. Run down the center of the arena past the end marker and do a right rollback—no hesitation.
6. Run up the middle to the opposite end of the arena past the end marker and do a left rollback—no hesitation.
7. Run past the center marker and do a sliding stop. Back up to the center of the arena or at least ten feet (three meters). Hesitate to demonstrate completion of the pattern.

Rider must dismount and drop the bridle to the designated judge.

# Heritage Reining Pattern—Short Stirrup

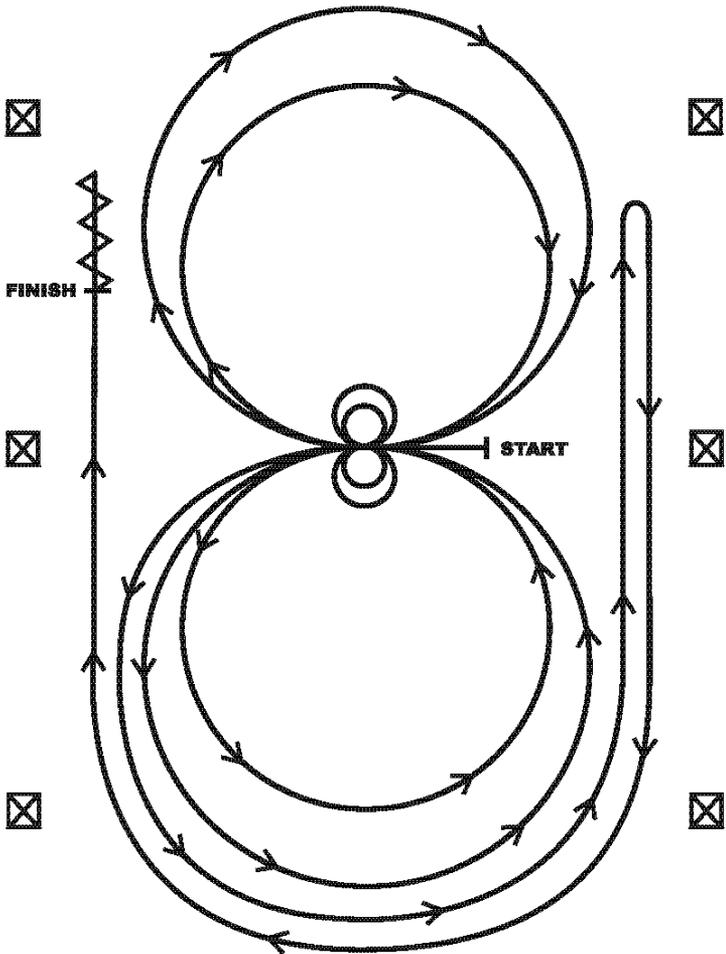

# Heritage Reining Pattern—Short Stirrup

*To be used as a modified pattern in the Heritage Circuit for Junior C only.*

Horses may walk or trot to the center of the arena. Horses must walk or stop prior to starting the pattern. Beginning at the center of the arena facing the left wall or fence.

1. Beginning on the left lead, complete two circles to the left. Stop at the center of the arena. Hesitate.
2. Complete two spins to the left. Hesitate
3. Beginning on the right lead complete two circles to the right. Stop at the center of the arena. Hesitate.
4. Complete two spins to the right. Hesitate.
5. Beginning on the left lead, go around the end of the arena, run down the right side of the arena past center marker, stop and roll back right.
6. Continue around the end of the arena to run down the left side of the arena past the center marker. Stop. Back up.

Rider must dismount and drop the bridle to the designated judge.

# Heritage Reining Pattern—Ranch Reining

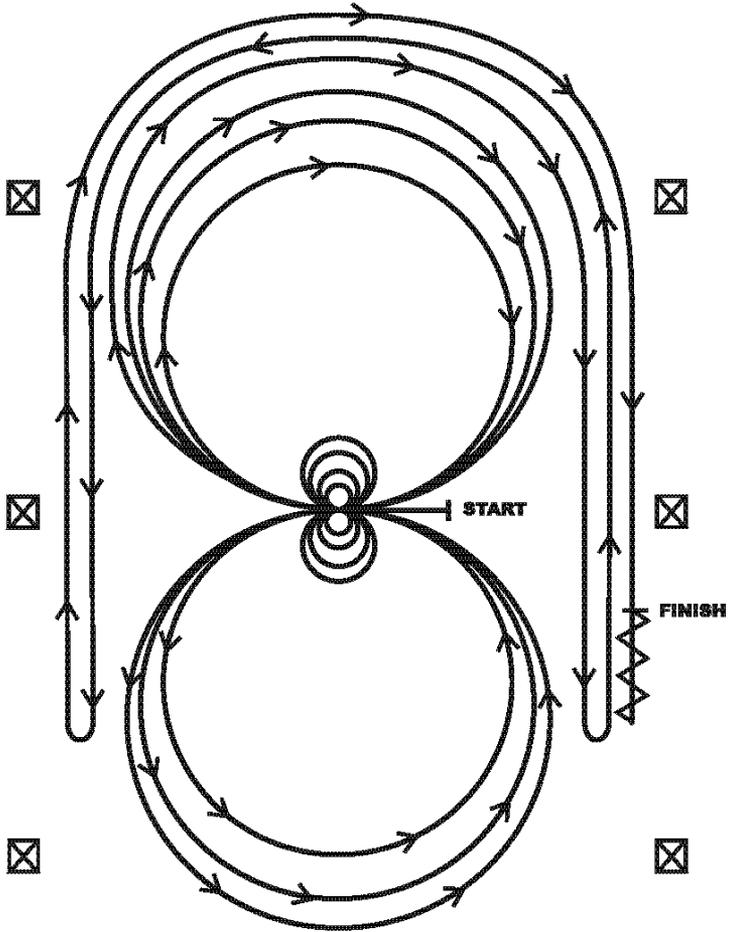

# Heritage Reining Pattern—Ranch Reining

Horses may walk or trot to center of arena. Horses must walk or stop prior to starting pattern. Beginning at center of arena facing left wall or fence.

1. Complete four spins to the left. Hesitate.
2. Complete four spins to the right. Hesitate.
3. Beginning on the right lead, complete three circles to the right: the first circle large and fast; the second circle small and slow; the third circle large and fast. Stop at the center of the arena. Hesitate.
4. Beginning on the left lead, complete three circles to the left: the first circle large and fast; the second circle small and slow; the third circle large and fast. Stop at the center of the arena. Hesitate.
5. Beginning on the right lead, run a large fast circle to the right but do not close this circle. Run straight down the right side of the arena past the center marker and do a left rollback at least twenty feet (six meters) from the wall or fence - no hesitation.
6. Continue back around the previous circle but do not close this circle. Run down the left side of the arena past the center marker and do a right roll-back at least twenty feet (six meters) from the wall or fence—no hesitation.
7. Continue back around the previous circle but do not close this circle. Run down the right side of the arena past the center marker and do a sliding stop at least twenty feet (six meters) from the wall or fence. Back up at least ten feet (three meters). Hesitate to demonstrate completion of the pattern.

Rider must dismount and drop bridle to the designated judge.

# Western Riding

---

## General

Western Riding is an event where the horse is judged on quality of gaits, lead changes at the lope, response to the rider, manners and disposition. The horse should perform with reasonable speed, and be sensible, well-mannered, free and easy moving.

One of four possible patterns as they appear in this handbook will be individually performed. The horse will be judged on quality of gaits, change of leads, response to the rider, manners, disposition, and intelligence.

1. Credit shall be given for and emphasis placed on:
  - a. **Smoothness**, even cadence of gaits (i.e., starting and finishing pattern with the same cadence), and the horse's ability to change leads precisely, easily and simultaneously both hind and front at the center point between markers.
  - b. **Balance**: In order to have balance, with quality lead changes, the horse's head and neck should be in a relaxed, natural position, with his poll level with or slightly above the level of the withers. He should not carry his head behind the vertical, giving the appearance of intimidation, or be excessively nosed out, giving a resistant appearance.
  - c. **Head Carriage**: The horse should have a relaxed head carriage showing response to the rider's hands, with a moderate flexion at the poll.
  - d. **Contact**: Horses may be ridden with light contact or on a reasonably loose rein. The horse should cross the log both at the jog and the lope without breaking gait or radically changing stride.
2. **The judge will select one of the four patterns that appear in this handbook to be performed. No other patterns may be used. The judge is responsible for the pattern being correctly set.**
3. On the pattern:
  - a. The eight small circles represent pylon markers which are recommended. These should be separated by a uniform measured distance of not less than 30 feet (9 m) nor more than 50 feet (15 m) on the sides with 5 markers (see diagram). In pattern one, the three markers on the opposite side should be set adjacent to the appropriate markers. It is recommended that markers be set

a minimum of 15 feet (4.5 m) from the fence and with 50 to 80 foot (15 to 24 m) width in the pattern, as the arena permits.

- b. A solid log or pole should be used and be a minimum of 8 feet (2.5 m) in length.
- c. The long serpentine line indicates the direction of travel and gaits at which the horse is to move. The shaded area represents the lead changing area between the markers. The dotted line (...) indicates walk, the dash line (- -) jog, and the solid line (-) lope.

## Class Conduct

Except for junior horses shown with a hackamore or snaffle, only one hand must be used and not be changed, except that it is permissible to change hands when opening gate if the gate is in such a position as to justify the change of hands on the reins. When a romal is used, it shall be carried as per ruling on [page 36](#) (Western Tack #2). Horses six years of age and older must be shown one handed in a bit.

## Scoring

Scoring will be on a basis of 0–100 with 70 denoting an average performance. Points will be added or subtracted from the maneuvers on the following basis, ranging from plus 1½ to minus 1½: -1½ extremely poor; -1 very poor; -½ poor; 0 average; +½ good; +1 very good; +1½ excellent. Maneuver scores are to be determined independently of penalty points.

### Five (5) Point Penalty:

- Out of lead beyond the next designated change area (failures to change, including cross-cantering). Two consecutive failures to change would result in two five-point penalties.
- Blatant disobedience including kicking out, biting, bucking and rearing
- Holding the saddle

### Three (3) Point Penalty:

- Not performing the specific gait (jog or lope) or not stopping when called for in the pattern, within 10 feet (3 m) of the designated area
- Simple change of leads
- Out of lead at or before the marker prior to the designated change area, or out of lead at or after the marker after the designated change area

- Additional lead changes anywhere in pattern (except when correcting an extra change or incorrect lead)
- In Pattern 1 and Pattern 3, failure to start the lope within 30 feet (9 m) after crossing the log at the jog
- Break of gait at walk or jog for more than two strides
- Break of gait at the lope

### **One (1) Point Penalty:**

- Hitting or rolling log
- Out of lead more than one stride either side of the center point and between the markers.
- Splitting the log (log between the two front or two hind feet) at the lope
- Break of gait at the walk or jog up to two strides

### **One-half (½) Point Penalty:**

- Tick or light touch of log
- Hind legs skipping or coming together during lead change
- Non-simultaneous lead change (front to hind or hind to front)

### **Disqualified Zero (0) Score:**

- Illegal equipment
- Willful abuse
- Off course
- Knocking over markers
- Completely missing log
- Major refusal (stop and back more than 2 strides or 4 steps with front legs)
- Major disobedience or schooling
- Failure to start lope prior to end cone in Pattern 1 and Pattern 3
- Four or more simple lead changes and/or failures to change leads
- Overturn of more than 1/4 turn

### **Credits**

- Change of leads, hind and front simultaneously
- Change of lead at the center point of the lead change area
- Accurate and smooth pattern
- Even pace throughout

- Easy to guide and control with rein and leg
- Manners and disposition
- Conformation and fitness
- Smoothness
- Performing the three required gaits
- The horse should cross the log both at the jog and the lope without breaking gait or radically changing stride

## **Faults**

The following characteristics are considered faults and should be judged accordingly in maneuver scores.

- Opening mouth excessively
- Anticipating signals or making early lead changes
- Stumbling
- Raising head on maneuvers
- Over-flexing or straining neck in head carriage so the nose is carried behind the vertical
- Excessive nosing out
- Losing stirrup or holding on
- Unnecessary talking, petting, spurring, quirting or jerking of the reins by the rider
- Failure to change leads

# Western Riding Pattern 1

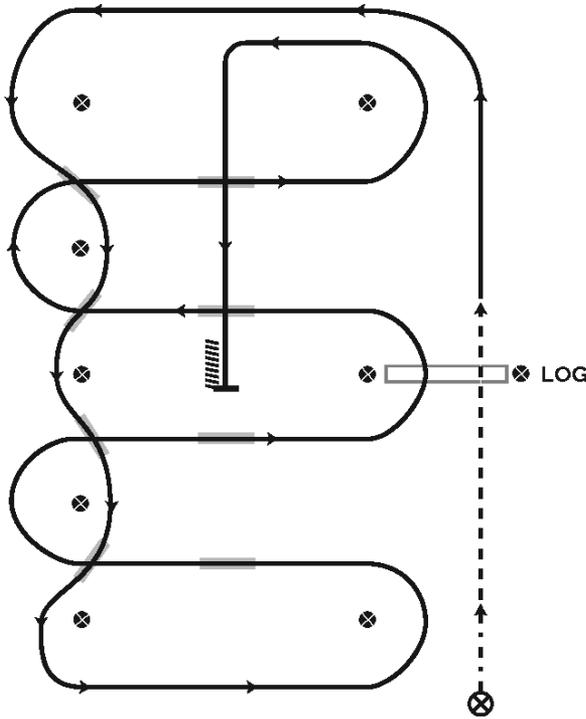

⊗ START CONE    WALK - - - - -    JOG - - - - -  
 LEAD CHANGING AREA █    LOPE ———

1. Walk at least 15 feet from start cone to the first marker. Start jogging at first marker and jog over log.
2. Transition to left lead and lope around end
3. First line change
4. Second line change
5. Third line change
6. Fourth line change lope around the end of the arena
7. First crossing change
8. Second crossing change
9. Lope over log
10. Third crossing change
11. Fourth crossing change
12. Lope up the center, stop and back

# Western Riding Pattern 2

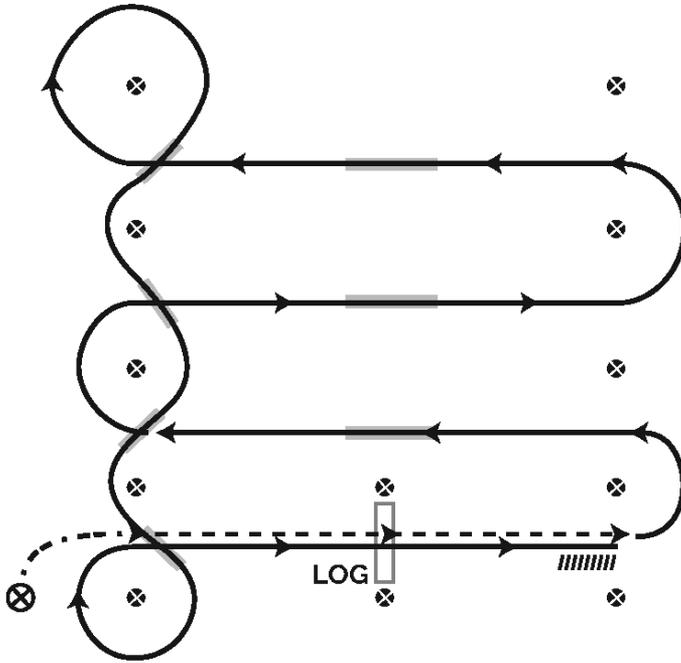

⊗ START CONE    WALK - - - - -    JOG - - - - -  
 LEAD CHANGING AREA     LOPE 

1. Walk, transition to jog, jog over log
2. Transition to lope, on the left lead
3. First crossing change
4. Second crossing change
5. Third crossing change
6. Circle and first line change
7. Second line change
8. Third line change
9. Fourth line change and circle
10. Lope, stop, and back

## Western Riding Pattern 3

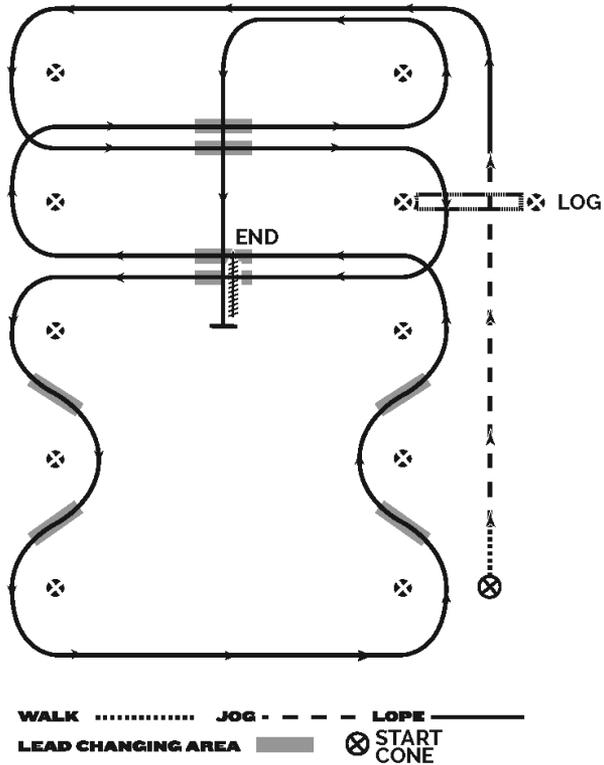

1. Walk halfway between markers, transition to jog, jog over log
2. Transition to the lope, on the left lead
3. First crossing change
4. Lope over log
5. Second crossing change
6. First line change
7. Second line change
8. Third line change
9. Fourth line change
10. Third crossing change
11. Fourth crossing change
12. Lope up center, stop and back

# Western Riding Pattern 4

For Junior B and C Riders Only

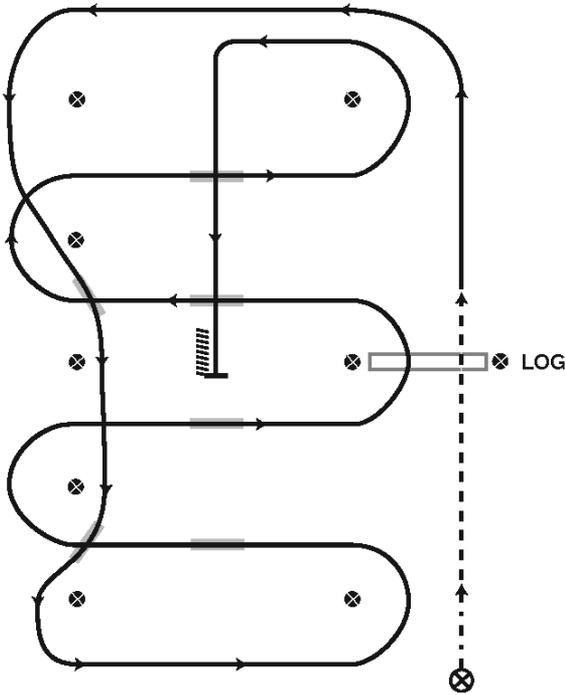

⊗ START CONE    WALK ———    JOG ———  
 LEAD CHANGING AREA ——— LOPE ———

1. Walk at least 15 ft, transition to jog and jog over log
2. Transition to left lead and lope around end
3. First line change
4. Second line change lope around the end of arena
5. First crossing change
6. Second crossing change
7. Lope over log
8. Third crossing change
9. Fourth crossing change
10. Lope up the center, stop and back

# Trail

---

## General

The Trail Horse Class is the performance of a safe, sensible, well-mannered horse over a course of obstacles.

## Class Conduct

1. Gaits between the obstacles shall be at the discretion of the judge. A flying lead change does not constitute an obstacle in a trail class. Any lead change or change of gait shall be judged under the scored gaits and way of going judging criteria. A flying lead change cannot be required, but it can be optional.
2. At least six obstacles will be used, three of which will be mandatory and at least three others selected from the approved list. Gait between the obstacles shall be at the discretion of the judge.
3. Horses must not be required to work on the rail. The course must be designed, however, to require each horse to show the three gaits: (walk, jog and lope) somewhere between obstacles as a part of its work and will be scored as a maneuver.
4. The course to be used must be posted at least one hour before scheduled time of the class.
5. Failure to follow the course, performing obstacles incorrectly or other than in specified order, or not attempting to perform an obstacle shall cause elimination.
6. If disrupted, the course shall be reset as each horse has worked.
7. Management, when setting courses, should keep in mind that the idea is not to trap a horse or eliminate it by making an obstacle too difficult. If difficult courses are set, junior trail should be less difficult.
8. Enough space must be provided for a horse to jog at least 30 ft (9 m), and to lope at least 50 ft (15 m), for the judge to evaluate these gaits.
9. The judge must walk the course and has the right and duty to alter the course in any manner. The judge may remove or change any obstacle he deems unsafe or non-negotiable.

# Obstacles

## Mandatory Obstacles

1. **Gate:** Opening, passing through, and closing the gate. Use a gate that will not endanger horse or rider. If the gate has a metal, plastic or wooden support bar under the opening, contestants must work the gate moving forward through it. Props positioned near the gate must not interfere with gate or latch.
2. **Logs or poles:** Ride over at least four logs or poles. These can be in a straight line, curved, zigzag or raised. The space between the logs is to be measured and the path the horse is to take should be the measuring point. All elevated elements must be placed in a cup, notched block, or otherwise secured so they cannot roll. The height should be measured from the ground to the top of the element. Spacing for walk-overs, trot-overs, and lope-overs should be as follows, or increments thereof:
  - a. **Walk-overs:** The spacing for walkovers shall be 20–24 in (50–60 cm) and may be elevated to 12 in (30 cm). Elevated walkovers should be set at least 22 in (55 cm) apart.
  - b. **Trot-overs:** The spacing for trot overs shall be 36–39 in (90–100 cm) and may be elevated to 8 in (20 cm).
  - c. **Lope-overs:** The spacing for lope overs shall be 6 to 6½ ft (1.8–2 m) or in increments thereof and may be elevated to 8 in (20 cm).
3. **Backing Obstacle:** Backing obstacles to be spaced a minimum of 28 in (70 cm). If elevated, 30 in (75 cm) spacing is required. Entrants cannot be asked to back over a stationary object such as a wooden pole or metal bar. Examples:
  - a. Back through and around three markers.
  - b. Back through L, V, U, straight or similar shaped course, it may be elevated no more than 24 in (60 cm).

## Optional Obstacles

1. Water hazard (ditch or small pond)
2. Serpentine obstacles at walk or jog—spacing a minimum of 6 ft (1.8 m) for jog
3. Animal dummies or silhouettes
4. Rubber stall or trailer mats
5. Carry object from one part of arena to another (articles such as coat or slicker as might be found on a trail ride)

6. Ride over wooden bridge minimum of 36 in (90 cm) width and 6 ft (1.8 m) length. Must be sturdy and safe.
7. Slicker - put on and remove
8. Mailbox - remove and replace materials from mailbox
9. Side pass – Poles may not be elevated
10. Square obstacle: Four logs or rails, 5–7 ft (1.5–2 m) long, laid in a square. Contestant enters the square by riding over log or rail as designated. When all four feet are inside the square, the rider should execute the indicated turn and exit the square.
11. A combination of two or more of any obstacles is acceptable.

## **Prohibited Obstacles**

- Tires
- Animals (**live, dead, or pieces of**)
- Hides
- PVC pipe
- Dismounting
- Jumps
- Rocking or moving bridges
- Water box with floating or moving parts
- Flames, dry ice, fire extinguisher, etc.
- Logs or poles elevated in a manner that permits them to roll
- Plastic or tarps

**The judge may remove or change any obstacle he/she deems unsafe or non-negotiable, or inappropriate for the level of competition.**

**Competitions that hire a separate judge for the trail portion of their show must have the main judge walk/inspect the trail course prior to the trail portion being judged.**

## **Scoring**

Scoring will be on the basis of 0 to infinity, with 70 denoting an average performance. A zero score cannot place.

Each obstacle will receive an obstacle score that should be added or subtracted from 70 and is subject to a penalty that should be subtracted.

Each obstacle will be scored on the following basis, ranging from plus 1½ to minus 1½: -1½ extremely poor; -1 very poor; -½ poor; 0 average; +½

good; +1 very good; +1½ excellent. Obstacle scores are to be determined and assessed independently of penalty points.

## **Penalties**

### **Zero (0) Score**

- Use of more than one finger between reins
- Use of two hands (except in snaffle bit or hackamore classes designated for two hands) or changing hands on reins; except for junior horses shown with hackamore or snaffle bit, only one hand may be used on the reins, except that it is permissible to change hands to work an obstacle
- Use of romal in front of cinch or used in a threatening way
- Performing the obstacles incorrectly or other than in specified order
- No attempt to perform an obstacle
- Equipment failure that delays completion of pattern
- Excessively or repeatedly touching the horse on the neck to lower the head
- Fall to the ground by horse or rider
- Failure to enter, exit or work obstacle from correct side or direction, including overturns of more than 1/4 turn
- Failure to work an obstacle in any manner other than how it's described by the course
- Riding outside designated boundary marker of the arena or course area
- Third refusal on course
- Failure to demonstrate correct lead or gait, if designated
- Faults that occur on the line of travel between obstacles, which will be cause for disqualification, except in novice amateur or novice youth classes, which shall be faults scored according to severity

### **One-half (½) Point Penalty**

- Each tick of log, pole, cone or obstacle.

### **One (1) Point Penalty**

- Each hit of or stepping on a log, pole, cone or obstacle
- Incorrect gait at walk or jog for two strides or less
- Both front or hind feet in a single stride slot or space
- Skipping over or failing to step into required space
- Split pole in lope-over

- Failure to meet the correct strides on trot over and lope over log obstacles

### **Three (3) Point Penalty**

- Break of gait at walk or jog for more than 2 strides.
- Out of lead or break of gait at lope (except when correcting an incorrect lead).
- Knocking down an elevated pole, cone, barrel, plant obstacle, or severely disturbing an obstacle
- Stepping outside the confines of, falling, or jumping off or out of an obstacle with one foot

### **Five (5) Point Penalty**

- Failure to follow the correct line of travel within or between obstacles
- Dropping slicker or object required to be carried on course.
- First refusal, balk, or attempting to evade an obstacle by shying or backing more than 2 strides away
- Letting go of gate or dropping rope gate
- Use of either hand to instill fear or praise
- Stepping outside the confines of, falling, or jumping off or out of an obstacle with more than one foot
- Blatant disobedience (kicking out, bucking, rearing, striking)
- Failure to complete obstacle.
- Second refusal
- Holding saddle

### **Faults**

Faults which occur on the line of travel between obstacles, scored according to severity:

- Over-flexing or straining neck in head carriage so the nose is carried behind the vertical
- Excessive nosing out
- Opening mouth excessively

# Walk-overs

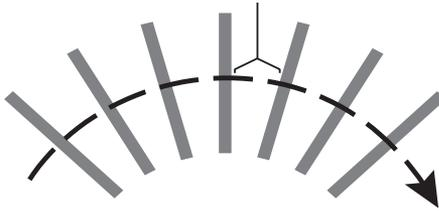
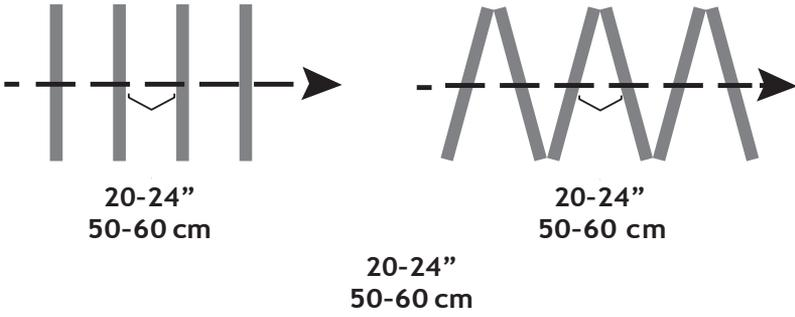

# Trot-overs

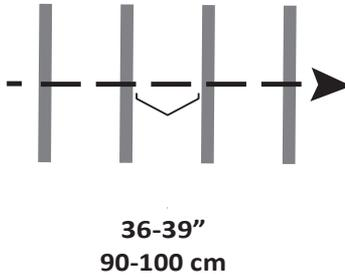

# Lope-overs

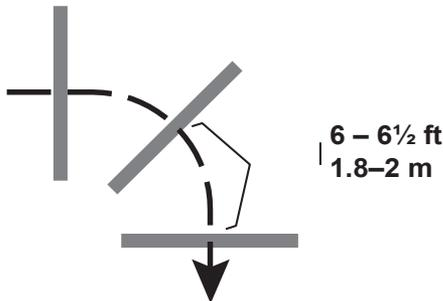

# Back Through and Around Three Markers

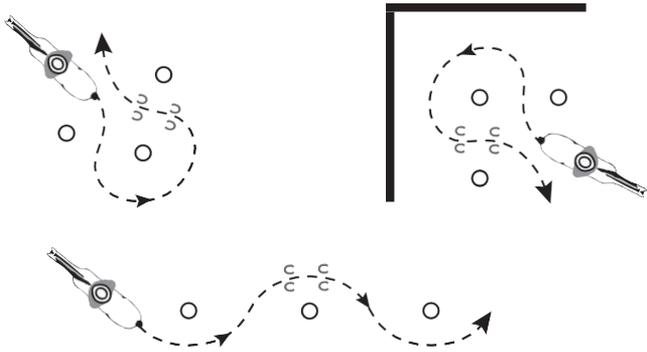

# Variations of Sidepass

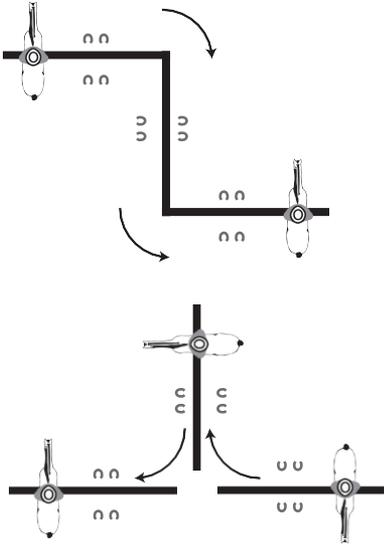

Front Feet Inside or  
Back Feet Outside

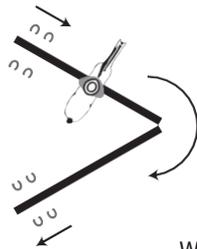

With Feet in Slot

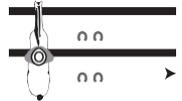

Sidepass Right  
Turn Right  
Sidepass Left

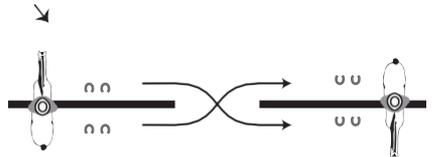
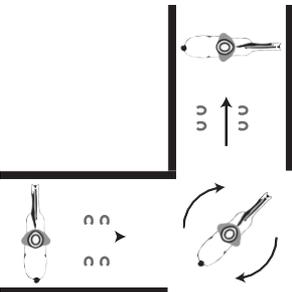

# Speed Division

---

## General

Speed events are races. Each competitor is attempting to negotiate the course as quickly as possible. Therefore, safety should be of paramount importance for both the rider and the horse.

## Class Conduct

1. Competitors in any individual event should compete in the same arena, on the same day, on the same measured course, and as nearly as possible, under the same conditions.
2. The order of go of the competition shall be determined by drawing lots, or by computerized random sorting.
3. Each contestant shall be ready when called or may be eliminated at the judge's discretion.
4. If there is an elimination heat(s) each horse must be ridden in the main go-round by the same rider who rode it in the elimination(s). Substitution of horses between heats is not permitted.
5. Ties will not be broken, except to determine class and championship winners. Money will be split equally between tied entries. A coin will be flipped to determine allocation of ribbons or other awards.
6. In the event of a run-off for a tie, the contestant declared the winner of a run-off must re-run the pattern within two seconds of his/her original time or the run-off must be re-staged.
7. Contestants must wait for direction from the ring steward, or activation of the green starting light before entering the arena or starting to run the pattern. Contestants must ensure they understand and obey all starting signals designated by the organizing officials.
8. Point accumulations for awards will accrue to horse/rider combinations only.
9. The judge, at his/her discretion, may eliminate a contestant for excessive use of a bat, crop, whip, or rope in front of the cinch.

## Courses

1. The Horse Show Committee must keep in mind that a properly prepared speed event horse will negotiate prescribed patterns correctly, at speed.

2. No element of a pattern should be adjacent to a fence or wall, if avoidable, and this will 'hold in' a horse that is incompletely trained.
3. Each course should be measured, element to element, and from the starting line.
4. Fences or walls should not be used as the starting point for measuring the course, unless the arena is too small for the standard pattern.
5. **Timing Line:**
  - a. Poles indicating the timing line, the event officials and equipment are not part of the course and should be as unobtrusive as possible.
  - b. Where practical, they should be outside of the arena enclosure. Otherwise, timing equipment, officials and start/finish line markers should be as close to the sides of the arena enclosure as is feasible. Barrels should not be used to mark the timing line, or to support the timing equipment. Chalk lines may not be used to signify the start/finish line.
  - c. **There should be two timers (one for backup)**
  - d. **High traffic areas should be raked after every fifth run.**
6. **Ground Conditions:**
  - a. As each competitor is attempting to negotiate the course as quickly as possible, the arena surface, therefore, must afford secure footing, at speed. If the surface is hard and/or slippery, it should be worked deeply enough to provide good footing. Any rocks, glass, sticks or other debris that might impair safety or injure the horses should be removed.
  - b. Periodic arena grooming (rakes or drag) should be provided, where the surface is subject to excessive pitting, to give the same footing to each horse.
  - c. Sufficient stopping distance should be provided beyond the finish line. See the individual event diagrams for recommended stopping distances.
7. **Entry/Exit:**
  - a. A course must be arranged to set up and finish in the arena. **No open gates.** The minimum distance from the timing line to the end of the arena shall be 50 feet (15.24 m).
  - b. Adequate space must remain between barrels and any obstacle. Refer to the individual event diagrams for recommended measurements.

## **Attire**

1. Tidy western dress is to be used at all times. Refer to 'Western Attire' on page 36.
2. In any speed event class, junior contestants are required (seniors encouraged) to wear an approved helmet.
3. Deliberate discarding of the hat by the competitor, anywhere in the arena, will incur a 5 second penalty, at the judge's discretion. It is recommended that hats be tied on in speed event classes.
4. Bats, crops, scat bats, spurs, over & under whips, nose and eyebrow tie-downs and mechanical hackamores are to be permitted.
5. Excessive spurring or cropping may bring elimination at the judge's discretion. Use of any other equipment that the judge considers too severe, or abusive striking of the horse around the head, will result in immediate elimination for that run.

## **Tack**

Western tack, except for bits, must be used. Bits are the option of the competitor but must be mounted in a Western style headstall. Properly fitted tie downs, martingales and draw reins are optional, but a halter must not be used in place of a proper noseband.

# Barrel Race

1. The official obstacle of Barrel Racing shall be a 45-gallon (200 liter) steel drum, with both ends closed.
  - a. If the course is too large for the available space the pattern should be reduced 15 feet at a time until the pattern fits the arena.
  - b. Rusty or damaged barrels that might provide a hazard for horses or riders must not be used.
  - c. No padding, or a tire, which might change the diameter, height or balance of the barrels, may be used.
2. Knocking over a barrel carries a five second penalty. Failure to follow course shall cause disqualification. A contestant may touch the barrel with his or her hands in barrel racing.

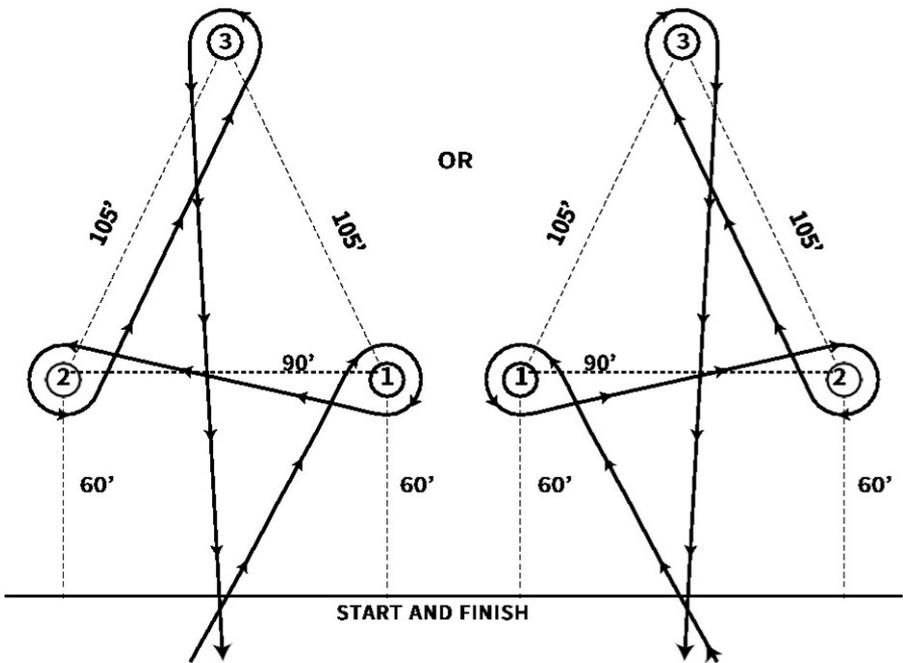

# Pole Bending

1. The official Pole Bending course is indicated in the diagram. The poles are placed on the center line of the arena, starting 21 ft from the timing line, with each successive pole a further 21 ft from the timing line.
  - a. The position of each pole must be precisely marked or measured so the course can be restored exactly after knockdowns.
  - b. Poles must always line up exactly.
2. The course may be run starting to the left or the right of the pattern, following the line of travel indicated on the diagram.
3. The course must start and finish inside the arena.
4. Failure to follow the correct course shall cause a disqualification.
5. Poles may be touched, but may not be held, carried, or relocated by contestants.
6. A 5-second penalty shall be assessed for each pole knocked down.

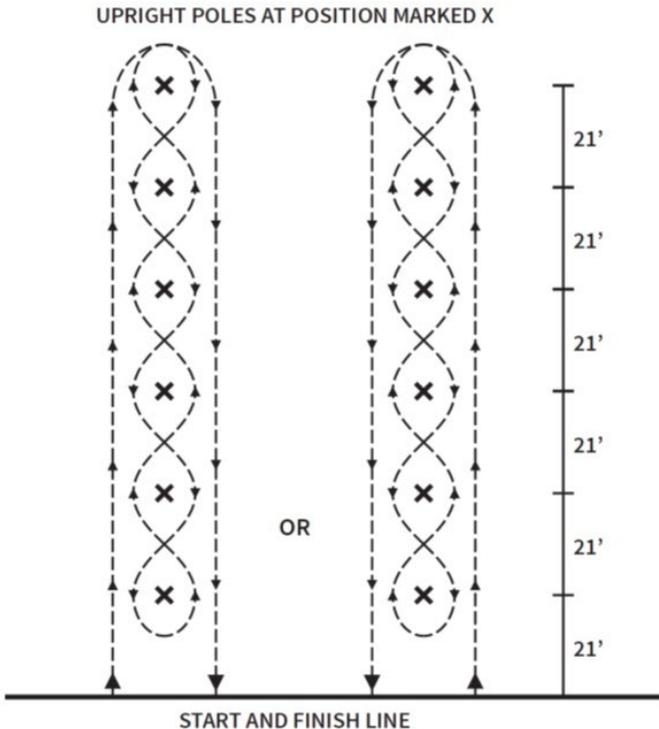

# Keyhole Race

---

1. The official obstacle of the Keyhole Race shall be a circle with a 20 ft (6.1 m) diameter. The entrance will be 4 ft (1.2 m) wide and 10 ft (3 m) long. The starting line may be from 50–100 ft (15.2–30.5 m) from the entrance to the circle.
2. The rider must turn the horse around in the circle. The rider is not permitted to walk the horse into or out of the circle. The horse is not permitted to touch or cross over the line when completing the key hole. Failure to follow the course or to step on or out of the circle line will result in elimination
3. The rider can start the pattern from either the left or right side.

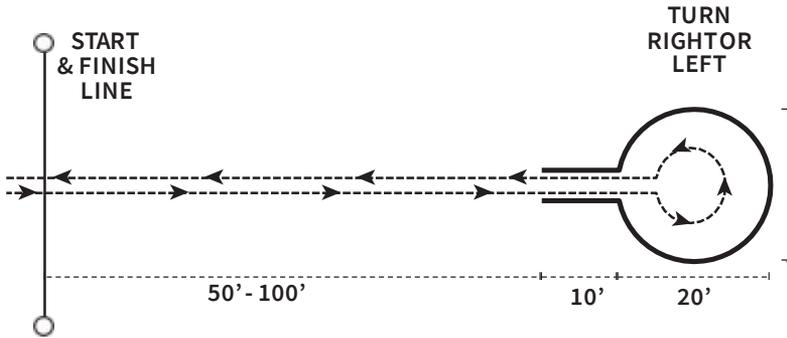

# Stake Race

---

1. This is a timed event. Timing shall begin as soon as the horse's nose reaches the starting line and will be stopped when the horse's nose passes over the finish line.
2. The contestant is allowed a running start and may begin his run from either the left or right side of the first pole. Start by crossing the center line between the upright markers, turn around the second pole, cross over the center line again between the markers, then around the first pole and run back across the finish line.
3. The start and finish line is 20 ft (6 m) wide and marked by two upright markers 10 ft (3 m) on each side of the center line and short enough so as to not interfere with the timer if one is used. Short pylons or cones are recommended. The first and second poles mark-

ing the center line are each 40 ft (12 m) from the start and finish line, making them a total of 80 ft (24 m) apart.

4. A five-second penalty will be assessed if the hat or approved protective headgear is not on the competitor's person for the entire time the competitor is in the arena in stake racing.
5. Failure of a contestant to cross the start and finish line between the markers shall result in no time.
6. Failure of contestant to cross over the center line between the markers before turning the second pole and cross back over the center line after turning the second pole, shall result in no time.
7. If an upright marker or pole is knocked down, it shall result in no time. If the original course is altered by a rider intentionally grasping a pole, a five-second penalty for each pole grasped will be assessed.
8. All horses must start from same end of arena.
9. If a tie occurs where points are involved, placing will be worked off if all tied competitors agree to participate in a run-off, if not, a coin toss will be used to separate the ties.

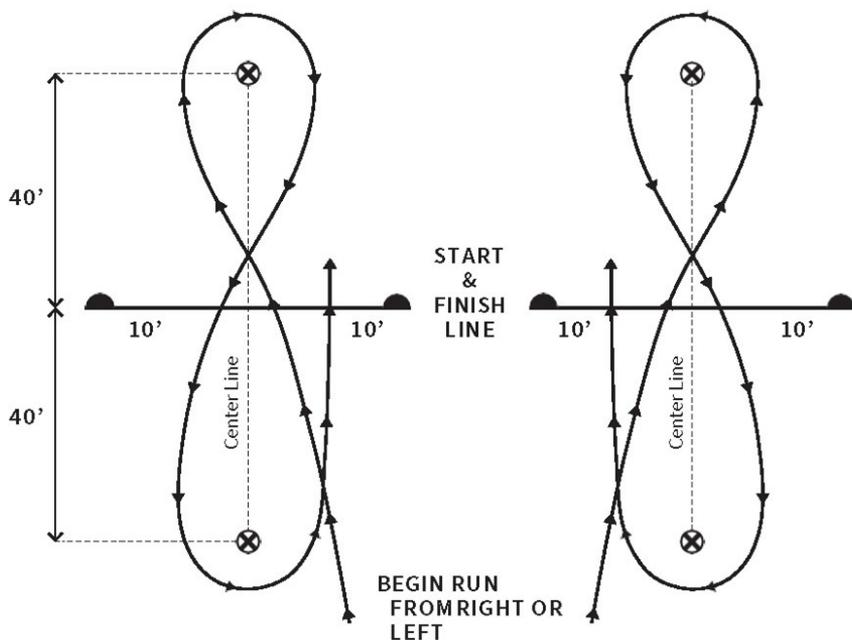

# Hack Division

---

## General

The hack division has been created to show the versatility of a horse or pony on the flat. The well-rounded hack horse or pony shows the versatility to perform well and adjust his way of going in each of these classes. Horses or ponies in this division may be of any breed or combination of breeds and must have natural action (not high and/or weighted).

## Tack

1. English saddle of any type is required.
2. Bridles may be double, pelham, snaffle or kimberwick.
3. Martingales, boots of any kind and/or bandages, breast collars and breast plates are not allowed.
4. Dropped and flash nosebands are prohibited.
5. Brow bands shall be leather of any description but not solid white, colored or sequined.

## Attire

1. Permitted Attire: Black jacket or dark coat, approved helmet with safety harness, conservative colored breeches, white hunting stock or chokers, black boots or smooth leather half chaps (no suede) with paddock boots. Tweed jackets are permitted at the option of the organizing committee.
2. Spurs are optional.
3. Whips are NOT permitted in any hack class.

# English Pleasure

---

## General Characteristics

An English Pleasure horse should have the distinct appearance of being a pleasure to ride. The horse should be relaxed and display impeccable manners. It should be forward moving and show a willing way of going at all gaits. The horse should have a bright expression and alert ears. It should be obedient on light hand and leg contact.

## Gaits

1. The **walk** is a four-beat flat-footed gait, alert and with a stride in keeping with the size of the horse.
2. The **trot** is a two-beat gait, it should seem effortless and be cadenced and balanced.
3. The **canter** is a three-beat gait, it should be smooth, with rhythmic and fluid strides. It should flow and be without excessive speed.

## Class Conduct and Judging

1. To be shown at a walk, trot and canter (not gallop).
2. The horse should exhibit a proper cadence at each gait with quality of movement and consistency of gait being of major importance. They should move with strides that cover the ground with ease. Transitions should be responsive and smooth.
3. The horse will be penalized for:
  - Break of gait or lead
  - Excessive speed at any gait
  - Being over flexed (behind the vertical)
  - Resistance or failure to take the appropriate gait when called for
  - Sour ears, tail wringing, excessive chewing
  - Failure to back in the lineup.
4. English Pleasure horses to be judged on quality of movement at 45%, manners at 40%, and conformation at 15%.

# Road Hack

---

## General Characteristics

Head well shaped, attractive and proportionate; mane may be roached; natural (not set) tail; strong; well-shaped neck with good length of rein; good strong sloping shoulders; medium high withers the same height as the croup; chest indicative of strength; moderately muscled forearm; back well-proportioned with height; powerful across the loin; good depth of girth; well-shaped proportionate quarters showing strength; sloping pasterns of good length; feet of proportionate size. The horse and pony must present an appearance of overall substance with refinement. Soundness is required, and blemishes may be penalized. Braiding of mane and tail is optional.

## Gaits

1. The **walk** is straight, four beat and flat-footed with medium contact.
2. The **trot** is straight and true, may be required as follows:
  - Normal on light to medium contact
  - Strong trot
3. The **canter** is normal on light to medium contact.
4. The **hand gallop** is under control with only 8 horses to gallop at one time.

## Class Conduct and Judging

1. Horses to enter the ring at a walk.
2. To be shown at a flat-footed walk with a reasonably loose rein, trot, strong trot, easy canter and hand gallop.
3. In Road Hack the most important judging criteria is performance, which makes up 55% of the score, followed by substance at 20%, conformation 15%, and manners at 10%.

# Show Hack

---

## General Characteristics

Head neat, finely drawn and elegant. Mane should not be roached and may be braided; neck of sufficient length with a trim throat-latch; neck to blend into shoulders which are medium width and not too heavily muscled; medium high and well-defined withers the same height as croup; chest well developed but in proportion; forearm not too heavily muscled; back moderately short but well-proportioned with height; moderately deep girth and well-shaped proportionate quarters; sloping pasterns of good length; feet of proportionate size. Show Hacks must have vitality, animation, presence, balance and clean fine limbs showing supreme quality. Soundness is required, and blemishes may be penalized. Braiding of mane and tail is optional.

## Gaits

1. The **walk** is straight, four beat and flat footed. No collected or extended gaits to be called for.
2. The **trot** is free, light and crisp, may be required as follows:
  - Collected—in contact with a more upright frame collected with the rider sitting
  - Extended—on contact, medium speed with legs moving forward with impulsion and the rider posting or sitting
3. The **canter** may be required as follows:
  - Collected
  - Normal
  - Extended
4. The **hand gallop** is under control with only 8 horses to gallop at one time.

## Class Conduct and Judging

1. Horses to enter the ring at a walk.
2. To be shown at a walk, trot, canter and hand gallop.
3. Collected and extended gaits are to be called for in trot and canter at discretion of the judge.
4. Horses are expected to stand quietly.
5. In Show Hack the most important judging criteria is performance, which makes up 55% of the score, followed by quality at 20%, conformation at 15% and manners at 10%.

# Dressage Division

---

## General

Dressage is an exhibition of riding in which the horse is controlled in certain maneuvers by very slight movement of the rider's hands, legs and weight in the saddle. Horses can be of any breed and size.

Dressage is shown at specific levels. These levels are progressively more difficult and reflect the development of the horse and rider's skills and abilities. The tests ridden in competition measure the horse and rider's schooling and correctness and are scored accordingly. Each level has a specified format which is stated on the test form. Each movement within the test is described and the elements to be performed are outlined.

Riders/horses performing **Introductory Level** tests should demonstrate a relaxed way of going and correct bend. The rider should use the correct basic aids and the horse should demonstrate its understanding of these aids by carrying himself forward and by accepting the bit. Required movements are medium walk, free walk, rising trot. All work is performed on 20 meter circles and straight lines.

At **Training Level**, the horses will be showing the working paces with some variation. Working infers a balance in which the horse is more or less on a horizontal plane. It should be carrying its own and its rider's weight evenly distributed throughout its body. A judge looks to see the horse is capable of maintaining a working balance in walk, trot and canter, and that it is working in relaxation, indicated by the smoothness of its transitions which, in turn, leads to accuracy.

**First Level** tests require that the horse has met the training level requirements and has developed further in terms of impulsion and balance. Horses are required to show lengthening of trot and canter, and display balance on smaller circles.

**Heritage Circuit competitions will use Equestrian Canada tests and will follow Equestrian Canada Dressage Rules.**

**Show Organizers:** If you do not have an EC sanctioned show, you must pay \$1 per test up to a maximum of \$20 to EC for the use of the tests. If you do not have internet access, contact the SHF Office.

**A horse/rider may compete in any two, but only two consecutive levels, and a horse may compete in a maximum of four tests per day (combined English and Western Dressage), including the Freestyle.**

# Attire

1. In keeping with the tradition and dignity of the sport, manes should be braided, unless roached, and dress and equipment neat and clean.
2. All Junior and Senior Dressage riders, regardless of the level they are competing at, must wear an approved helmet.
3. A dark or gray colored jacket (short or tailcoat) or tailored dressage vest with a long or short sleeved shirt. Contrasting collars, points, pin stripes and piping are allowed.
4. White or light-colored breeches, black or brown boots, tie, hunting stock or choker, and gloves.
5. Juniors are permitted to wear jodhpurs and boots. Spurs are optional.
6. Riders with long hair must wear hair nets or tie hair back in a braid or bun.
7. In the case of inclement weather, and at the judge's discretion, competitors may wear a suitable hat cover and a warm or waterproof overcoat. In extreme heat or humidity, the judge may permit competitors to ride without jackets.

# Tack & Equipment

1. A plain English saddle, black or brown color only, with stirrups is compulsory in all levels.
2. All bridles must be English style and correctly fitted, reins must be only black or brown in color. The Micklem Bridle without clips or lunging rings is permitted. Only snaffle bits are allowed. Introductory through First Level allows a snaffle bridle with one of the following nosebands: drop, regular cavesson, flash, figure 8, or crescent.
3. Type of reins is optional, attachment to the bit may be by buckle, stud or rings, but reins with hand loops, elastic or stretchy rubber inserts or any other attachment are prohibited. Reins must not be made of rope or ropelike material. Reins may be laced, plain, rolled, or rubber lined on one or both sides. Reins may have hand stops.
4. Whips not exceeding 1.2 meter in length may be used, except at a championship show.
5. Martingales (other than running), bit guards, any kind of gadgets, any form of blinkers, and seat covers are under penalty of elimination and strictly forbidden on the show grounds at any time during any competition.

6. Ear Hoods are permitted and may also provide noise reduction. However, hoods should be discreet in color and design. Ear Plugs are forbidden.
7. Boots or bandages may not be worn in the competition.
8. Breastplates, foregirths, girth covers, cruppers and non-restrictive nose fly guards are permitted.
9. The use of two-way communication devices in the competition arena is prohibited.

## Scoring

10 – Excellent

9 – Very Good

8 – Good

7 – Fairly Good

6 – Satisfactory

5 – Sufficient

4 – Insufficient

3 – Fairly Bad

2 – Bad

1 – Very Bad

0 – Not Performed

½ Points may also be awarded

### The collective marks are based on:

1. The freedom and regularity of the horse's movement (gaits).
2. The horse's desire to move forward with elasticity of steps and roundness (impulsion).
3. The horse's attention and confidence, harmony with the rider, lightness of movement and acceptance of the bit (submission).
4. The rider's correctness and effectiveness of aids (position and seat).

## Faults and Eliminations

Riders will incur faults or eliminations for:

- Disobediences
- Excessive resistance
- Use of illegal equipment
- Inappropriate tack or attire
- Fall of horse or rider during test
- Dangerous or unruly behavior of horse
- All four feet of horse leaving the arena area
- Lameness
- Taking excessive time to enter the arena after the signal. Not entering the arena within 45 seconds after the signal, but

within 90 seconds, is considered an error and two points will be deducted. Horse and athlete combinations not entering the competition arena within 90 seconds after the signal will be eliminated

- Evidence of blood on horse
- For a more extensive list of Faults and Eliminations see the Equestrian Canada Rule Book at <https://www.equestrian.ca/programs-services/rules>

## Arena

1. The arena must be flat and level and should be predominantly sand footing. The standard arena size is 20 x 60 meters.
  - a. For Introductory and Training Level tests ONLY, the arena size of 20 x 40 meters may be used.
  - b. For First Level and above, the arena size of 20 x 60 meters must be used.
2. The arena should be separated from the public by a distance of 15 meters surrounding the arena if possible.
3. The arena itself should be surrounded by a low fence about 0.30 meters high. The part of the fence at 'A' should be easy to remove to allow the competitor in and out of the arena in a suitable way. The rails of the fence should be such to prevent the horse's hooves from entering.
4. The letter markers outside the ring enclosure should be placed about 0.5 meters from the fence and clearly marked. It is desirable to put a special mark on the inside of the fence itself, level with, and in addition to, the letter concerned. The part of the fence at A can remain open. The letter A must be placed at least 5 meters away from the arena and a distance of up to 15 meters is permitted.
5. Arena fence conditions must be the same for all competitors in a class.
6. The center line, through its length, and the three points D, X and G are desirable (but not mandatory) and must be clearly marked, but not to frighten the horse.
7. The judge must have a separate table that is raised, if possible, to give him/her a good view of the arena.

# Small Dressage Arena

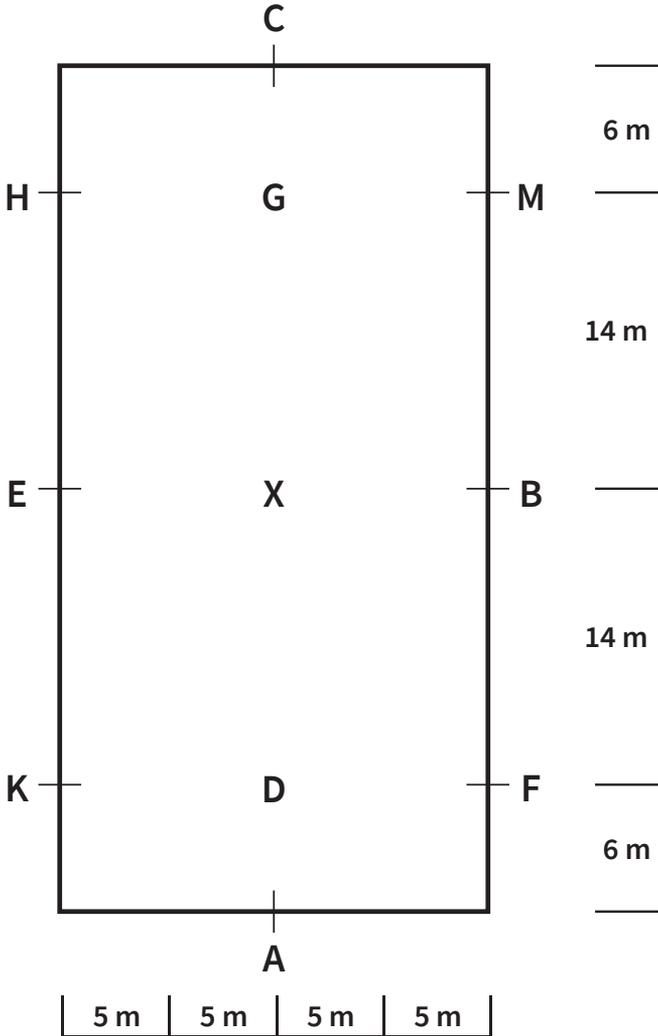

# Large Dressage Arena

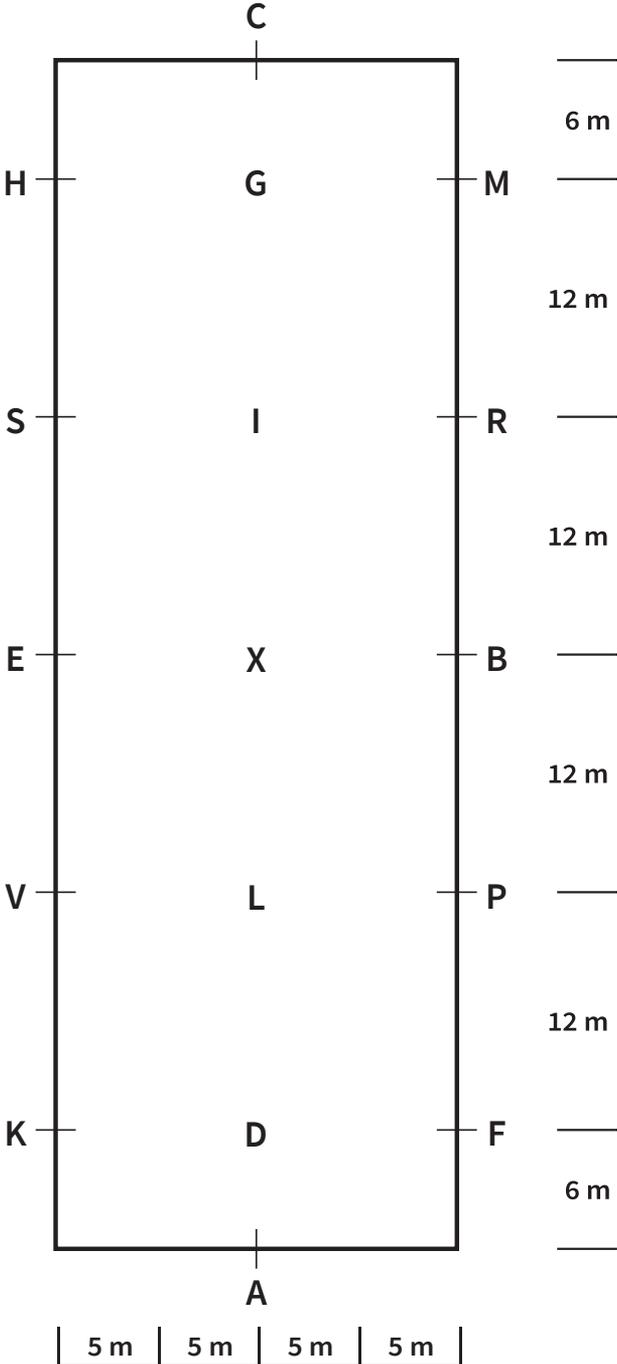

# **Western Dressage Division**

## **General**

Western dressage horses can be of any breed or size. They should display a harmonious partnership with their riders by performing tests in a balanced, supple and obedient manner. The horse should also demonstrate a calm and confident manner while giving the appearance to be happy at its job. A well ridden test will demonstrate free flowing movement, comfortable strides and balance. Rhythm and cadence will be regular. The overall appearance of a good Western Dressage test will be one that shows lightness and harmony.

Gaited horses will be judged in a separate class.

**Heritage Circuit Western Dressage classes will use WSDAC Tests and follow the rules of the current WSDAC rule book.** Tests and rules can be found at [www.westernstyledressage.ca](http://www.westernstyledressage.ca).

**Show Committees are required to submit all scores as well as placings for Western Dressage classes to the SHF, and to WSDAC if the show is also sanctioned by WSDAC.**

**A horse/rider may compete in any two, but only two consecutive levels, and a horse may compete in a maximum of four tests per day (combined English and Western Dressage), including the Freestyle.**

## **Attire**

1. Riders will wear a long sleeve shirt or blouse (with any type of collar), trousers and boots. Short sleeves may be worn at the discretion of the judge.
2. All Junior Dressage riders, regardless of the level they are competing at, must wear an approved helmet. Senior Dressage riders may wear a western hat or an approved helmet.
3. Optional equipment, such as vests, jackets, sweaters, neckerchiefs and chaps are also acceptable attire.

## **Tack**

Western dressage is ridden in a western style saddle. Horses may be ridden two handed in a snaffle bit, or a shanked bit. A hackamore may also be used. Refer to General Rules for Western Style Dressage Association of Canada.

# Arena

The size of the arena should be 20 x 60 meters. Introductory and Basic levels may use an area measuring 20 x 40 meters. The footing in the arena should be level, and letters must be set to designate where movements are to be made.

# Scoring

The horse's movement is to be judged based on freedom and regularity of gaits. A horse should show a desire to move forward with impulsion, roundness, and elasticity of steps. A horse should demonstrate submission by overall attention to the rider. Acceptance of the bit, lightness of movements, and overall harmony will be considered. The rider's position and seat will be evaluated for correctness, effectiveness of aids, and ability to perform accurate movements.

10 – Excellent	4 – Insufficient
9 – Very Good	3 – Fairly Bad
8 – Good	2 – Bad
7 – Fairly Good	1 – Very Bad
6 – Satisfactory	0 – Not Performed
5 – Sufficient	½ Points may also be awarded

# Faults and Eliminations

Riders will incur faults or eliminations for:

- Disobediences
- Excessive resistance
- Use of illegal equipment
- Inappropriate tack or attire
- Fall of horse or rider during test
- Dangerous or unruly behavior of horse
- All four feet of horse leaving the arena area
- Lameness
- Taking excessive time to enter the arena after the signal. Not entering the arena within 45 seconds after the signal, but within 90 seconds, is considered an error and two points will be deducted. Horse and athlete combinations not entering the competition arena within 90 seconds after the signal will be eliminated
- Evidence of blood on horse
- For a more extensive list of Faults and Eliminations see WSDAC Rule Book at <https://westernstyledressage.ca/wsdac-tests-%2F-rules>

# Hunter Division

---

## General

A hunter should display good jumping form and be calm and confident while doing so. The horse should move with a steady rhythmic canter between the fences and jump the fence in a manner that appears to flow. The pace should be even throughout the course and the horse should adjust its leads accordingly. The horse should meet the fence squarely and jump in the center of the obstacle. A hunter should be relaxed but show a willing and alert attitude. It should remain calm on its approach to the jump and continue on course quietly after landing. A good hunter completes the course with cadence, balance and style in a manner that is comfortable and safe.

**A horse/rider combination may compete in a maximum of three consecutive heights per day.**

**A horse may compete in a maximum of four over fences classes per day which applies to combined Hunter and Jumper classes including specials, classics, derbies, stakes, medals, or equitation over fence (not including Hunter warm ups, Jumper clear-rounds and hors concours rounds). Hunter classics and hunter specials that are 2 round classes will count as one over fences class. Jumper classes that include a jump off will count as one over fences class.**

**“Hors concours” rounds are allowed at the discretion of the judge and/ or show committee. Hors concours riders will pay a regular entry fee and will follow all rules pertaining to the competition. They will not be eligible for awards. A horse or pony that has competed “HORS CONCOURS” is not permitted to be judged in the same ring on the same day. A horse or pony may only compete “HORS CONCOURS” once in the same ring on the same day.**

**A horse is limited to one round per class and may not be ridden by more than one rider in that class.**

**An exhibitor may ride up to three different horses in any one class.**

## Headgear

At competitions offering over fences classes, proper protective headgear (helmet) with safety harness permanently affixed to the helmet is compulsory for everyone riding anywhere on the competition ground. It is

mandatory that the protective headgear meets the ASTM/SEI standards and displays the applicable seal.

## **Safety/Medical Services**

It is mandatory that all competitions where persons are required to jump over obstacles have Emergency Medical Service on site. There should be a minimum of advanced first aid and basic cardiac life support (BCLS) provided. The presence of an ambulance is not required. A crisis response plan should be prepared in advance by the show committee.

## **Tack & Equipment**

1. Hunter classes (both under saddle and over fences) have requirements for classic, plain tack that demonstrates that the hunter is easy to ride, attentive and responsive to its rider.
2. The saddle is usually a type of forward seat (jumping saddle), generally the style called 'close contact'. Saddles are usually of brown leather.
3. Girth should be plain, preferably leather. Sheepskin on the girth is permissible.
4. The saddle pad (numnah) should be white and shaped to fit the saddle. A half pad is permissible.
5. The bridle is simple, with a plain cavesson (any type of noseband other than a plain cavesson is prohibited) and a simple, unadorned browband.
6. Bits are also simple, usually a classic snaffle bit, either a dee-ring, egg-butt, or full cheek design. A double bridle, pelham or kimberwick may also be used. Bit converters may only be used in junior and amateur classes 3' and under. Milder bits are preferred in hunter classes.
7. Loop reins are not permitted.
8. Martingales either standing or running (with rein stops) may be used in over fences classes. Hunting breastplates are permissible.
9. Bandages and boots are not allowed in hunter rounds but may be used in equitation classes. In inclement weather bandages or boots may be allowed at the discretion of the judge.
10. Whips cannot exceed 75 cm (29.5 in) and must be un-weighted.
11. The use of earphones or earbuds or other communication devices are strictly prohibited in the competition arena.

## Attire

1. The hunt coat should be of traditional style and conservative color (navy, gray, hunter green, or dark brown).
2. Breeches should be light colored.
3. Traditional black boots should be worn but paddock boots (black or brown) may be used with matching smooth leather half chaps (no suede). Younger riders may wear paddock boots with jodhpur pants and straps.
4. The shirt (rat catcher) should be white or a light pastel color.
5. Dark gloves should be worn and are required for equitation classes.
6. Hair must be neat and contained in a net or braid.
7. At the discretion of the judge, mandatory use of hunt coats may be waived if weather is excessively hot or humid.
8. No sweatshirts, t-shirts or tank tops are permitted. Shirts must be neatly tucked into breeches.

## Grooming and Braiding

1. The hunter horse must be very neat and well presented. They should have their manes (and sometimes tails) braided for showing.
2. If braiding is not possible, the mane is to be neatly pulled to lie flat on the horse's neck.
3. If braiding the tail, it should be braided into a French style braid that runs the length of the tail bone, with the remainder of the tail allowed to flow freely.
4. Horses should have any long body hair trimmed short, particularly around the fetlocks, jaw, muzzle and ears.

## Hunter Courses

1. **The SHF strongly recommends the use of technical assistance when setting over fences classes at a competition. Please contact the SHF office for more information and a list of approved course designers.**
2. Course designers are encouraged to build courses that are not overly complicated and that reflect the abilities of the horses and riders at the competition.
3. A hunter course should typically consist of 8–10 obstacles. The course should be simple and inviting and should include verticals, oxers, gates and fences with natural fill such as brush and flowers.

Fences should simulate those found in a field, such as natural looking rails, brush, walls and coops. The fences should be natural colors such as brown, green, beige and white. Solid fences with lots of fill and a well-defined ground line are easier to jump.

- a. Jumps with spread (oxers) must have the back rail higher than the front. The height of the fences should not exceed that listed for the class. For example, if it is a 2'6" hunter class, the back rail of the oxer must not exceed that height.
  - b. There are no oxers in Cross rail and 2' Hunter classes.
  - c. Maximum height for Cross rail fences is 18" at the center to provide a safe and inviting jump. Cross rail heights may be adjusted (at the judge's or course designer's discretion) for beginner horses, beginner riders or ponies. Any adjustments must be made prior to the start of the class.
4. **Plastic jump cups and pins must be used.** Breakaway jump cups on tracks may be used. **Metal jump cups and/or pins are forbidden.**
  5. Hunter courses for Heritage Circuit classes should use traditional component tracks (or 'lines') of side, diagonal and quarter-line wherever possible. A simple bending line may be used in an equitation course. **Refer to sample courses on pages 107-110.**
  6. Hunter distances are typically based on a 12-foot stride. Adjustments should be made according to the height of the fences being jumped (i.e., slightly lengthen the distances between related obstacles as the height of the fences goes up).
    - a. Adjustments may also be made according to ring size, and footing (e.g., depth or weather conditions).
    - b. Slope of the arena and whether or not the fences are set going away from or toward the in-gate may also affect stride length.
  7. Horse shows offering over fences classes must provide a safe warm-up area (preferably fenced) with a minimum of one straight (vertical) and one spread (oxer) fence for practice. Flags to indicate direction are required (red flag on right side and white on left).
  8. No competitor will be allowed to set or use this equipment outside of the scheduled show time or designated schooling times.
  9. Shows offering hunter classes are also encouraged to allow time for schooling rounds. The times for rounds will be determined by the Show Committee and will be dependent on the facility as well as the availability of equipment and emergency medical services.

# **Class Conduct**

1. Hunter courses must be clearly posted a minimum of 30 minutes prior to start of class.
2. Horses are shown, one at a time, over a course of hunter style obstacles.
  - a. At the discretion of the Competition Management, and if course design permits, 'pre-loading' of the hunter ring is permitted. The gate person will control this process.
3. A performance starts when the horse enters the ring and ends when it leaves.
4. Awards will be given once all horses have completed the course.

# **Judging**

A hunter is judged on movement, manners, jumping style/performance and hunting soundness. At the judge's discretion, horses may be asked to trot for soundness.

# **Jumping Style/Performance**

A good show hunter must possess an excellent jumping form. The fore-arm should be parallel with, or higher than the ground. The knees and lower legs should be even. The horse should not be lazy with its lower legs but tuck them under its forearm as it clears the fence, clearly bending its fetlocks and knees. The horse should not throw its body or legs to one side but should stay perfectly straight over the fence. A good hunter should show a great 'bascule' or roundness, over a jump.

# **Movement**

A good hunter should cover the ground effortlessly with long, low sweeping strides. It should be able to collect and lengthen its stride while maintaining its tempo and rhythm.

It should not have excessive knee action, nor should its strides be short and choppy, both of which would make its movement less efficient.

1. The walk should be free and ground covering.
2. The trot should show balance and cadence and be ground covering without excessive speed.
3. The canter should display long, low strides that cover the ground with relaxed, free-flowing movement.

## Manners

A hunter should display an alert and willing attitude. It should be relaxed and responsive to invisible signals from its rider and it should present an overall appearance of being easy to ride. The horse should be obedient to light hand and leg cues. Transitions should be smooth and on cue.

## Soundness

A hunter must display hunting soundness and must be free from any sign of lameness.

## Scoring

1. Horses will be credited for maintaining an even hunting pace while covering the ground with free-flowing strides. Preference will be given to horses that meet the fence squarely, at the center of the fence, and jump with correct jumping style.
2. Circling once upon entering the ring and once before leaving is permitted. Horses shall be rewarded for entering and exiting the ring at a relaxed walk.
3. Horses will be penalized for unsafe jumping and bad form, whether or not they touch the fence. Twisting, incorrect leads and cross-cantering will be penalized. Adding a stride between fences of a related distance will be penalized. Leaving out a stride is considered dangerous and will be heavily penalized. Further penalties may be incurred by excessive speed or slowness, breaking gait, excessive opening of the mouth, kicking out, spooking or shying, pinned ears or tail wringing, and swapping leads when not asked for.
4. Excessive use of the whip will result in penalties. A rider may be disqualified for striking a horse more than twice.
5. Refusals and knockdowns will be heavily penalized. An obstacle is considered knocked down when the height is lowered by the horse or rider through contact with the rail or standard.

**Scoring of hunters is based on 1-100. With the following breakdown:**

**90-100:** An excellent performer and a good mover that jumps the entire course with cadence, balance and style.

**80-89:** An excellent performer that commits one or two minor faults: or, a good performer that jumps all fences reasonably well.

**70-79:** A good performer that makes a few minor faults: or an average

mover that making no serious faults but lacks the style and cadence of the scopier horse.

**60-69:** Poor movers that make minor mistakes such as cross canter: or average movers that have no major faults or disobediences but had one or two poor fences.

**50-59:** A horse that commits one major fault, such as refusal, break of gait, drops a leg, showing bad jumping form. Rider touching horse with whip.

**30-49:** A horse that commits two or more major faults, such as knock downs, refusal, dangerous jumping.

**10-29:** A horse that avoids elimination but jumps in a manner that is dangerous.

## **Disobediences**

1. Refusal: When a horse stops in front of an obstacle (whether or not it is knocked down). If the horse is moved toward the obstacle but does not attempt to jump, it is considered another refusal.
2. Run-out: When a horse evades or passes the obstacle to be jumped.
3. Loss of forward movement: When a horse fails to maintain the trot or canter after beginning the course.
4. Unnecessary circling on course: When a rider circles his/her horse in such a manner that its original track between two consecutive obstacles (anywhere on course) is crossed. The exception to this is if the horse is retaking an obstacle after a refusal or run-out.

## **Elimination**

- Two disobediences including refusal, stop, run-out, or extra circle
- Bolting from the arena
- Being off course
- Jumping an obstacle before it is reset
- Fall of horse and/or rider. A horse is considered to have fallen when shoulder and haunch on the same side touch the ground. The rider may not remount.

# Hunter Under Saddle Class

---

Heritage Circuit shows wishing to offer proper hunter divisions should include a Hunter Under Saddle class. Under saddle classes should only be run if a minimum of two over fences classes are offered in a corresponding height division. Points earned in under saddle classes are not considered for Heritage awards.

For example, a Hunter Division would consist of:

- 2'6" Hunter Over Fences Class
- 2'6" Hunter Under Saddle Class
- 2'6" Hunter Stake Class

Horses must compete in the over fences portion of the division in order to ride in the under saddle class for that division.

Hunter Under Saddle classes should not be the first class of a hunter division. The horse should be judged over fences before the flat portion of that division.

## Class Conduct

Horses from a particular hunter division will show together in the flat portion. They will be shown at a walk, trot and canter, both ways of the ring. At the judge's discretion, they may be asked to extend gaits (no more than eight horses to hand gallop at one time).

## Judging

Horses are to be judged on their performance, condition and conformation. They should possess the same quality of movement as described for a good hunter. A flowing, balanced performance that shows cadence and willingness shall be given maximum credit. Transitions should be smooth and responsive.

Horses will be faulted for:

- Short, quick, vertical strides
- Break of gait
- Wrong lead
- Excessive speed or slowness at any gait
- Failure to take appropriate gait when called for
- Stumbling
- Being dull, lethargic or emaciated
- Carrying head too high or low (poll above or below withers)

# Miscellaneous Hunter Classes

---

Points earned in these classes count toward Heritage (or Prairie Cup Awards). If multiple heights are jumped in the same class, results must indicate what height was jumped by each competitor.

## Hunter Derby

1. The purpose of the Hunter Derby is to:
  - Return hunters to their hunt field roots
  - Take hunters to the International level
  - Promote hunters as a spectator sport
  - Revive traditional horsemanship and add excitement to the hunter ring
2. Courses are designed to more closely resemble the hunt field. There are fewer ground lines, taller, narrower fences, ditches, gates, banks, walls and hedges. Most derbies are set and run in the jumper ring.
3. In a Hunter Derby, the approach to the jumps varies greatly. There may be lines that are short, long or serpentine and the decision on how to ride these is completely negotiable.
4. Riders are rewarded for choosing more difficult routes, which can include optional jumps.
5. Hunter Derbies differ from traditional hunter classes primarily in the construction of the fences and the track between them.

## Hunter Classic

1. This class is only open to horses that have shown in at least one other hunter class at the competition.
2. Competitors are allowed to walk the course prior to jumping.
3. The class is to be shown over two hunter rounds.
  - a. The first round will consist of approximately 10 fences and each participant will be given a numerical score (out of 100). The top eight horses will return for the second round.
  - b. The second round is a shortened course. The top eight will return in reverse order of their numerical score achieved in the first round (lowest score will go first).
4. Final placings will be determined by adding the scores of both rounds.
5. Horses must be stripped and jogged for soundness.

## **Hunter Special**

The Hunter Special is a class that is run similar to the Classic except that it is only one round. Scores will be announced after each round and awards will be given after all competitors have completed their course.

# Heritage Hunter Course 1

Cross rails to 2'6"

Oxers at 2'3" and 2'6" ONLY

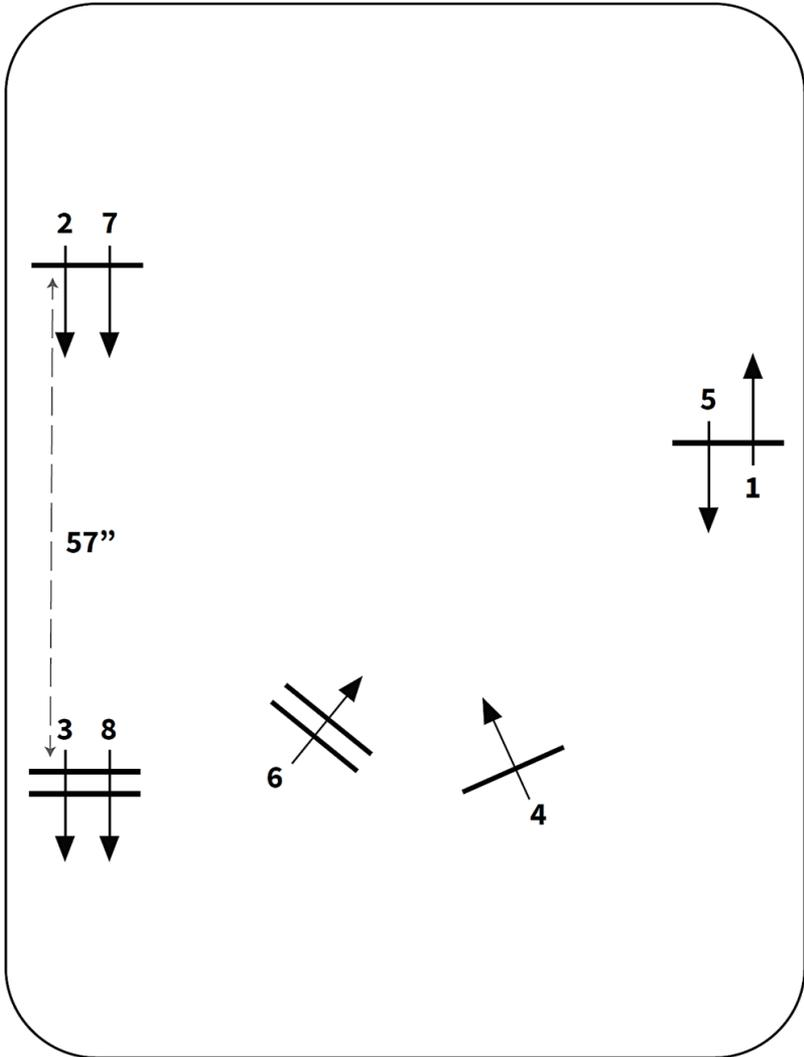

# Heritage Hunter Course 2

Cross rails to 2'6"

Oxers at 2'3" and 2'6" ONLY

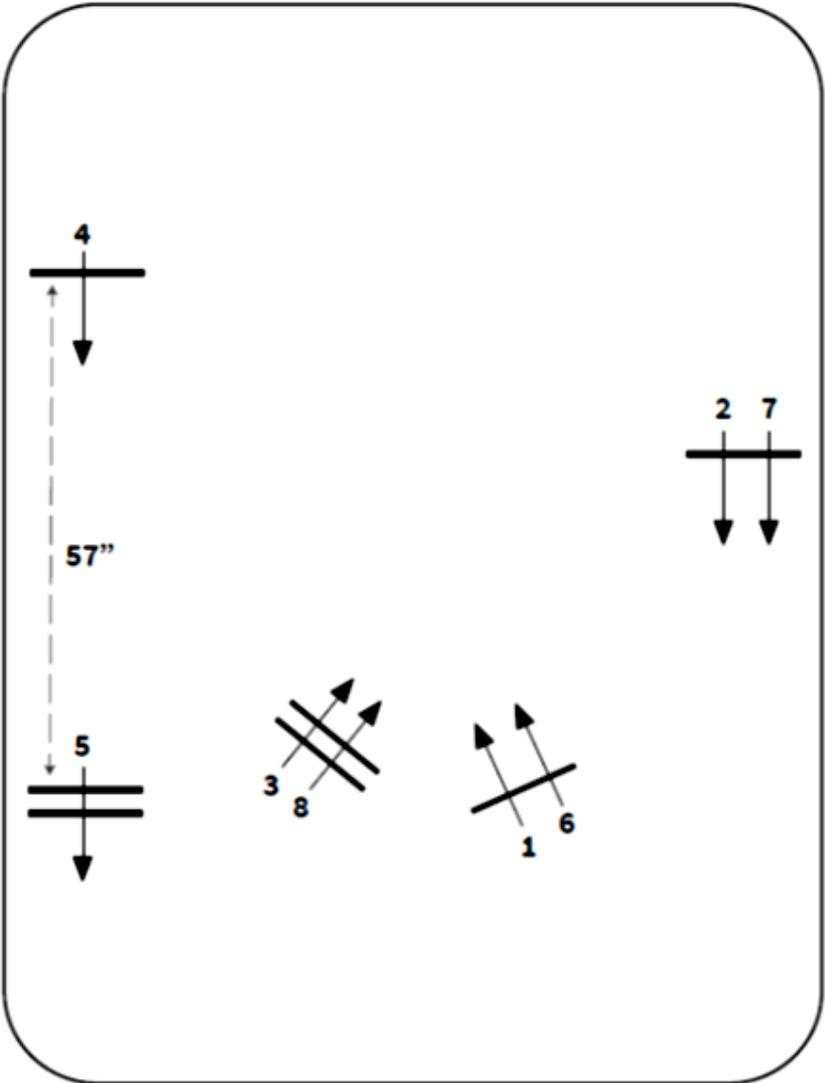

# Heritage Hunter Course 3

Cross rails to 2'6"

Oxers at 2'3" and 2'6" ONLY

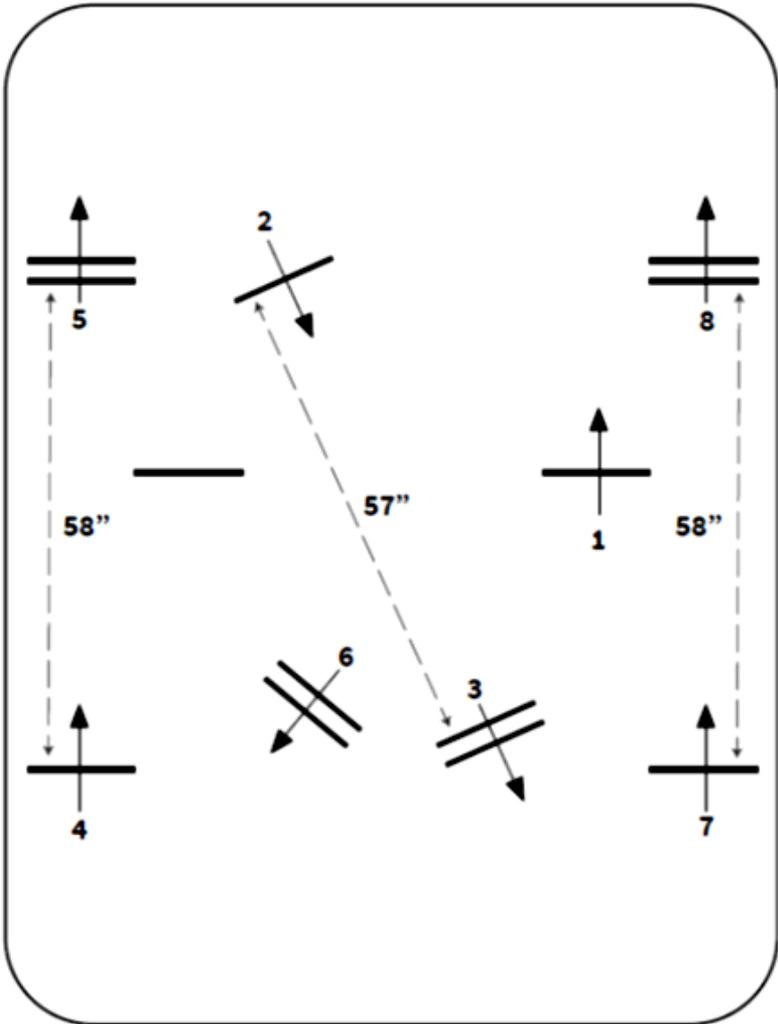

# Heritage Hunter Course 4

Cross rails to 2'6"

Oxers at 2'3" and 2'6" ONLY

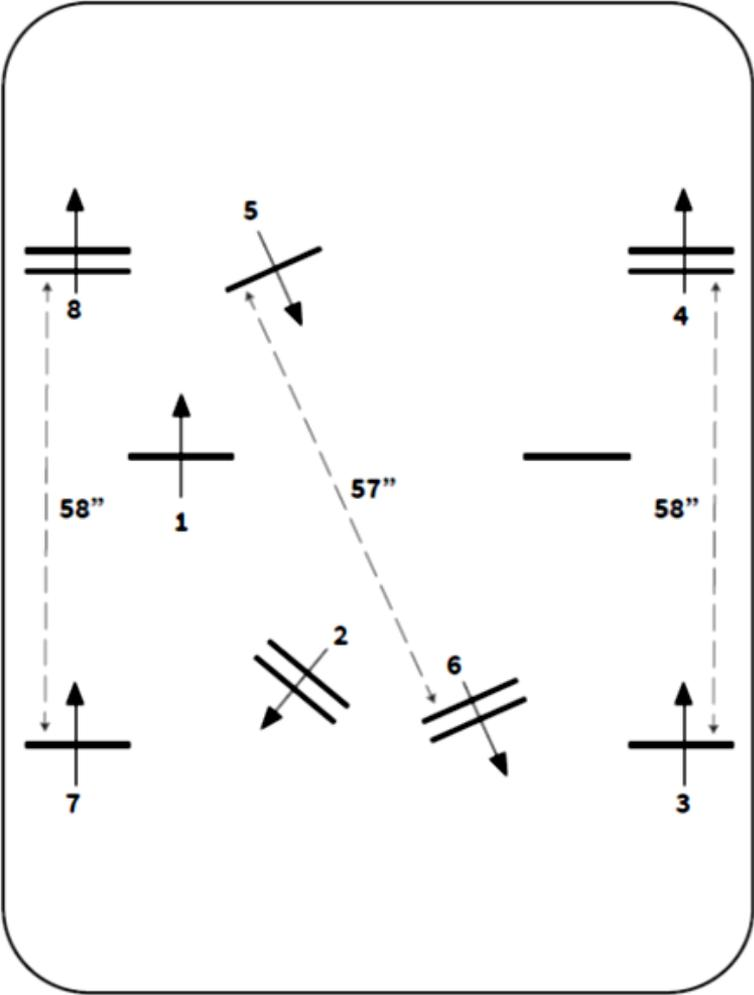

# Equitation Division

## General

In this division, only the rider or handler is judged on their way of riding or handling the horse. It is their skill that is being assessed and judged and not that of the horse. The horse is merely the tool used to help the person perform.

This division allocates points to the rider or handler only. A rider or handler will not receive points for more than one entry in any given class at a show. Points won in the Equitation Division are used only in the calculation of the Equitation Awards.

**Medal classes do not count towards Equitation Points or any other awards.**

## Western Horsemanship

1. Riders will be judged on seat and hands, ability to control and show the horse.
2. Results as shown by performance of the horse are NOT to be considered more important than the method used by the rider.
3. Rider should sit in center of saddle with legs under rider forming a straight vertical line through ear, center of shoulder, center of hip and back of heel. Stirrup length should allow heels to be lower than toes, with slight bend in knee, and toe directly under knee. Body should always appear comfortable, relaxed, and flexible, and back should be nearly flat. Stiff or arched lower back should be avoided. Feet may be placed home in the stirrup, with boot heel touching the stirrup, or may be placed with ball of foot in the stirrup. Riding with toes only in stirrup will be penalized.
  - a. **Hands:** Both hands and arms shall be held in a relaxed easy manner, with the shoulders back and down, and upper arm in a straight line with the body, the arm holding the reins bent at elbow forming a straight line from the elbow to the horse's mouth. When using a romal, the rider's off hand shall be around the romal with at least 16 inches of rein between the hands. Wrists are to be kept straight and relaxed, with thumb on top and fingers closed around the reins. One finger between the reins is permitted when using split reins, but not with a romal.

Some movement of the arm is permissible, but excessive pumping will be penalized. Reins are to be carried immediately above or slightly in front of saddle horn. Only one hand is to be used for reining, and hand shall not be changed. Reins should be carried so as to have light contact with the horse's mouth and at no time shall reins be carried more than a slight hand movement from the horse's mouth. In the event that a horse five years of age or younger is shown with a snaffle bit or hackamore, it is legal for a rider to show with two hands on the reins.

- b. Position in Motion:** Rider should sit to trot and not post. At the lope he/she should remain seated. Rider should maintain vertical position at all gaits. All movements of horse should be governed by the use of imperceptible aids. Exaggerated shifting of the rider's weight is not desirable. Moving of the lower legs of riders who are short shall not be penalized.

## Scoring

Exhibitors are to be scored from 0 to infinity, with 70 denoting an average performance. Patterns will be divided into 6 to 10 maneuvers, as specified by the judge, and each maneuver will be scored from +3 to -3 with 1/2 point increments acceptable that will be added or subtracted from 70. Maneuver scores should be determined independent of penalties, and should reflect equal consideration of both performance of the exhibitor's pattern and the horsemanship form and effectiveness of the exhibitor to result in the following scores:

- +3 Excellent
- +2 Very Good
- +1 Good
- 0 Average or Correct
- 1 Poor
- 2 Very Poor
- 3 Extremely Poor

Exhibitors overall horsemanship form and effectiveness should also be scored from 0 to 5 with 0 to 2 Average, 3 Good, 4 Very Good, 5 Excellent. Exhibitors should also be judged on the rail, and their pattern score and/or ranking may be adjusted as appropriate.

## **Penalties**

An exhibitor should be penalized in the pattern independent of maneuver scores and deducted from the final score as follows:

### **Three Points:**

- Break of gait at the walk or jog up to 2 strides
- Over or under turn from 1/8 to 1/4 turn
- Tick or hit of cone
- Obviously looking down to check leads

### **Five Points:**

- Not performing the specific gait or not stopping within 10 feet (3 meters) of designated location
- Incorrect lead or break of gait at the lope (except when correcting an incorrect lead)
- Break of gait at walk or jog for more than 2 strides
- Loss of stirrup
- Bottom of boot not touching pad of stirrup at all gaits including backup
- Head carried too low and/or clearly behind the vertical while the horse is in motion, showing the appearance of intimidation

### **Ten Points**

- Loss of rein
- Use of either hand to instill fear or praise while on pattern or during rail work
- Holding saddle with either hand
- Cueing with the end of the romal
- Blatant disobedience including kicking, pawing, bucking, and rearing
- Spurring in front of the cinch

### **Disqualifications (cannot place)**

- Failure to display correct number
- Abuse of horse or schooling
- Fall by horse or exhibitor
- Illegal equipment or illegal use of hands on reins
- Use of prohibited equipment
- Off pattern, including knocking over or wrong side of cone or marker; never performing designated gait or lead; over or under turning more than 1/4 turn

# Tack & Attire

Clothing must be clean, workmanlike and neat. The saddle must fit the rider. It may be slick or swelled fork, having a high or low cantle, but most definitely sized to the rider. **See Western Attire on page 36.**

# Class Conduct

1. The judge will ask each rider to work individually. The individual works will be any of the maneuvers the judge feels are necessary to determine the horsemanship ability of the rider.
2. **Tests:** Individual work may be composed of any of the following:
  - Walk, jog, trot, lope or gallop in a straight line, a curve, a circle, or any combination of these gaits and patterns, such as a figure eight, etc.
  - Stop
  - Back
  - Side pass
  - Counter canter
  - Turn on the haunches, including spins and rollbacks, or turn on the forehand
  - Simple change of lead through the trot, walk, halt, in a straight line, figure 8 or any other pattern OR flying change of lead in a straight line, figure 8, or any other pattern
3. Use of markers helps to standardize patterns and guide riders, but they also increase the degree of difficulty somewhat, so their placement should be carefully planned and indicated in the posted pattern, and their placement in the arena well supervised.
4. The judge must post the pattern he/she will ask for at least one hour prior to the class commencing.
5. Judging of individual work will begin at the indication of the judge.
6. The judge will use these individual works to determine the top riders to be called back for rail work.
7. The Horsemanship class is to determine the riding ability of the rider, and the judge will bear this in mind at all times.

# Showmanship at Halter

---

1. The Showmanship class shall be judged strictly on the exhibitor's ability to fit and show a horse at halter. The horse is merely a prop to demonstrate the ability and preparation of the exhibitor. The ideal showmanship performance consists of a poised, confident, neatly attired exhibitor leading a well-groomed and conditioned horse that quickly and efficiently performs the requested pattern with promptness, smoothness, and precision. The Showmanship class is not another halter class and should not be judged as such.
2. It is mandatory that the judge post any patterns to be worked at least one hour prior to the commencement of the class; however, if the judge requires additional work of exhibitors for consideration of final placing, the finals pattern may not be posted. Patterns should be designed to test the showman's ability to effectively present a horse to the judge. All ties will be broken at the judge's discretion.
3. For the purpose of the Heritage Circuit, competitors in Showmanship classes may be dressed in either Western or English attire. If in English attire, horse may be in either bridle or halter. All Junior participants must wear a helmet.
4. Exhibitors are to be scored from 0 to 100 with ½ point increments acceptable. Ten points should be allocated toward the overall appearance of the exhibitor and the horse and 10 points allocated toward performance.

## Tack & Attire

See English Attire on page 35 and Western Attire on Page 36

## Scoring

Exhibitors are to be scored from 0 to infinity, with 70 denoting an average performance. Patterns will be divided into 6 to 10 maneuvers, as specified by the judge, and each maneuver will be scored from +3 to -3 with 1/2 point increments acceptable that will be added or subtracted from 70. Maneuver scores should be determined independent of penalties, and should reflect equal consideration of both performance of the exhibitor's pattern and the form and effectiveness of the exhibitor and presentation of horse to result in the following scores:

- +3 Excellent
- +2 Very Good
- +1 Good
- 0 Average or Correct
- 1 Poor
- 2 Very Poor
- 3 Extremely Poor

Exhibitors overall form and effectiveness should also be scored from 0 to 5 with 0 to 2 Average, 3 Good, 4 Very Good, 5 Excellent.

## **Faults**

An exhibitor should be penalized in the pattern independent of maneuver scores and deducted from the final score as follows:

### **Three Points**

- Break of gait at the walk or trot up to 2 strides
- Over or under turning up to 1/8 of a turn
- Ticking or hitting cone
- Sliding a pivot foot
- Lifting a pivot foot during a pivot or set-up and replacing it in the same place
- Lifting a foot in a set-up and replacing it in the same place after presentation

### **Five Points**

- Not performing the specific gait or not stopping within 10 feet (3 meters) of designated location
- Break of gait at walk or trot for more than 2 strides
- Splitting the cone (cone between the horse and exhibitor)
- Horse stepping out of or moving the hind end significantly during a pivot or turn
- Horse stepping out of set-up after presentation
- Horse resting a foot or hipshot in a set-up
- Over or under turning 1/8 to 1/4 turn

## **Ten Points**

- Exhibitor is not in the required position during inspection
- Exhibitor touching the horse or kicking or pointing their feet at the horse's feet during the set-up
- Standing directly in front of the horse
- Loss of lead shank, holding chain or two hands on shank
- Blatant disobedience including kicking, rearing or pawing; horse continually circling exhibitor

## **Disqualifications (cannot place)**

- Loss of control of horse that endangers exhibitor, other horses, or judge
- Horse becomes separated from exhibitor
- Failure to display correct number
- Willful abuse Excessive schooling or training; use of artificial aids
- Illegal equipment
- Off pattern, including knocking over or wrong side of cone or marker; never performing designated gait; over or under turning more than 1/4 turn

# The Quarter Method

The following guidelines are meant to serve as an illustration of movement around the horse while showing in Showmanship at Halter and are for the exhibitor's information.

Imaginary lines bisect the horse into four equal parts (numbered I, II, III, IV for ease of identification). One line runs across the horse, just behind the withers. The other imaginary line runs from head to tail. When the judge is in I the handler should be in IV. As the judge moves to II, handler should move to I. When the judge moves to III, the handler moves to IV. As the judge moves up the horse to IV, the handler returns once more to I. This method is based on safety as the handler can keep the horse's hind-quarters from swinging toward the judge should the horse become fractious.

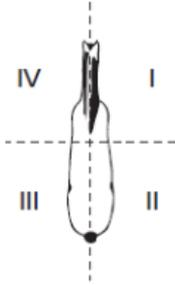

# English Equitation

---

1. Any of the recognized seats may be used in an English Equitation class.
2. Riders will be judged on seat, hands and legs, and their ability to control and show their horse.
3. The class will proceed at least once around the ring at each gait—walk, trot, sitting trot and canter—and on command will reverse and repeat.

4. Following the rail work, the class will line up and perform individual tests at the judge's discretion. Individual tests from which the Judge may choose:
- Stop
  - Rein back
  - Figure 8 at a trot, demonstrating change of diagonals
  - Figure 8 at a canter with a simple lead change through trot (three or four trotting steps)
  - Extended trot or medium trot
  - Turn on the haunches
  - Change of leads on a straight line down the center line with a simple change through the trot or walk

## **Tack & Attire**

See English Attire on page 35

## **Scoring**

Exhibitors are to be scored from 0 to infinity, with 70 denoting an average performance. Patterns will be divided into 6 to 10 maneuvers, as specified by the judge, and each maneuver will be scored from +3 to -3 with 1/2 point increments acceptable that will be added or subtracted from 70. Maneuver scores should be determined independent of penalties, and should reflect equal consideration of both performance of the exhibitor's pattern and the equitation form and effectiveness of the exhibitor to result in the following scores:

- +3 Excellent
- +2 Very Good
- +1 Good
- 0 Average or Correct
- 1 Poor
- 2 Very Poor
- 3 Extremely Poor

Exhibitors overall equitation form and effectiveness should also be scored from 0 to 5 with 0 to 2 Average, 3 Good, 4 Very Good, 5 Excellent. Exhibitors should also be judged on the rail, and their pattern score and/or ranking may be adjusted as appropriate.

## **Penalties**

An exhibitor should be penalized in the pattern independent of maneuver scores and deducted from the final score as follows:

### **Three Point**

- Break of gait at the walk or trot up to 2 strides
- Tick or hit of cone
- Obviously looking down to check leads or diagonals

### **Five Point**

- Not performing the specific gait or not stopping within 10 feet (3 meters) of designated location
- Missing a diagonal up to 2 strides
- Incorrect lead or break of gait at the canter (except when correcting an incorrect lead)
- Complete loss of contact between rider's hand and the horse's mouth
- Break of gait at walk or trot for more than 2 strides
- Loss of iron
- Head carried too low and/or clearly behind the vertical while the horse is in motion, showing the appearance of intimidation

### **Ten Point**

- Loss of rein
- Missing a diagonal for more than 2 strides
- Use of either hand to instill fear or praise while on pattern or during rail work
- Holding saddle with either hand
- Blatant disobedience including kicking, pawing, bucking, and rearing

### **Disqualifications (cannot place)**

- Failure by exhibitor to wear correct number in visible manner
- Willful abuse of horse or schooling
- Fall by horse or exhibitor
- Illegal use of hands on reins Use of prohibited equipment
- Off pattern, including knocking over or wrong side of cone or marker; never performing designated gait, lead, or diagonal

# **Hunt Seat Over Fences**

---

The objective of this class is to judge the rider's ability over fences, not the horse's. Only the effect the rider has on the horse, and their overall effectiveness is to be considered. Attention will focus on the rider's position between and over fences. How the rider elects to ride the course, the pace and approach to the jumps, and their ability to get the horse to the right take-off spot are used to evaluate the rider's ability.

## **Tack & Attire**

Riders will ride in Hunter tack and attire. [See English Attire on page 35](#)

## **Course Description**

An Equitation Over Fences course should be similar to a basic hunter course. It should allow the rider to test his/her skills while keeping to the standards of a good hunter round. The course may include a bending line or a roll back. It may be set up so that the rider can elect to approach the fence from two different lines. If the rider chooses the route with the higher degree of difficulty, he/she may earn extra points. However, the overall picture must remain rhythmic and flowing.

## **Class Conduct**

1. Class routine will be the same as for hunters but may include a ride off where the top riders may be called back to be individually tested. This may be done on the flat and/or over fences.
2. Elimination incurred during a ride off shall result in that competitor being placed last of all ride off participants.

## **Individual Tests**

It is suggested that individual tests be kept simple. Judges may choose from the flat tests plus the following:

- Pull up between fences (except in a combination)
- Jump low fences at a walk, trot or canter

# Heritage Hunt Seat Over Fences Course

Trot at markers (\*) and to Fence 9

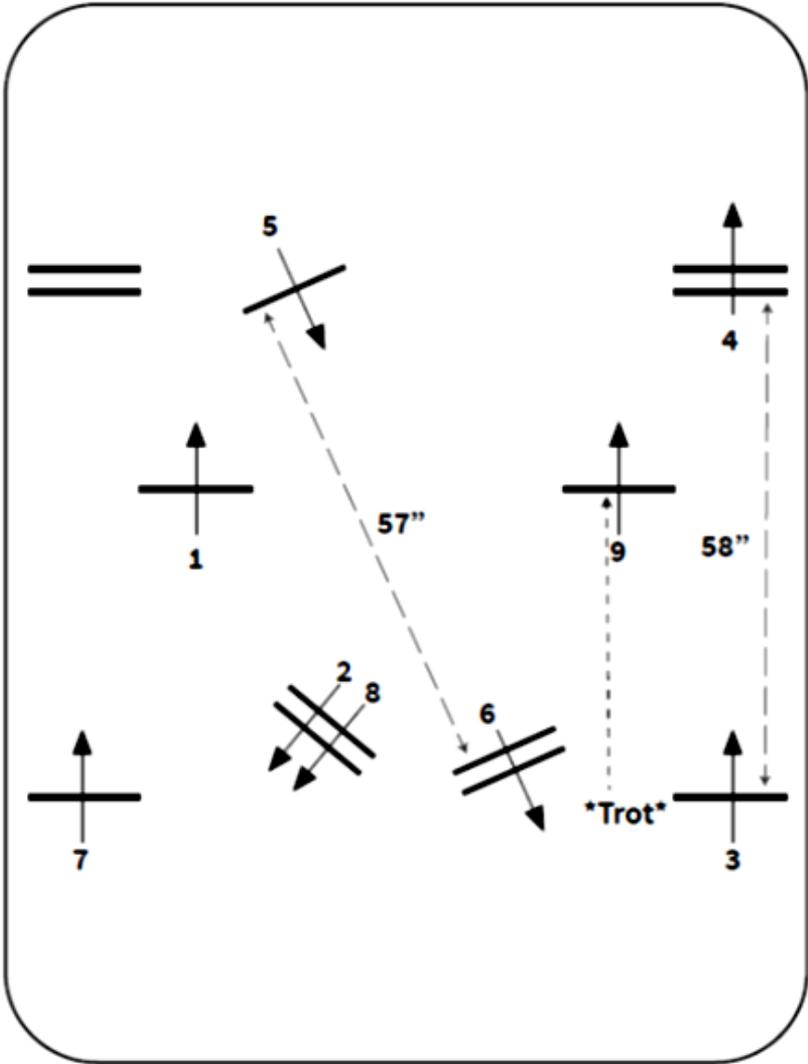

# Ranch Division

---

## General

Heritage Circuit Ranch classes will follow current AQHA Rules. See the current AQHA Rulebook for patterns.

Approved classes:

- Working Western Rail
- Ranch Riding
- Ranch Trail

Classes may be Open, Senior or Junior.

**Officials shall be SHF Senior or Primary, or Guest Carded Breed Officials qualified in the Ranch Division.**

Apparel & Equipment:

- No hoof polish or hoof black.
- No braided or banded manes/tails or tail extensions.
- Trimming inside ears is discouraged.
- Trimming bridle path is allowed, also trimming of fetlocks or excessive (long) facial hair.
- Equipment with silver should not count over a good working outfit. Excessive silver on bridles and saddles is discouraged.
- It is suggested competitors use a breast collar and a rear cinch.
- When exhibiting in a snaffle bit or hackamore, an exhibitor may switch between two hands and one hand on the reins at any time.

# **Additional Classes**

---

## **Pleasure Driving**

---

These classes are for a single horse hitched to a cart.

### **General Safety**

1. All persons involved in the competition should keep safety foremost in their minds. Having the horse under control at all times not only is a safeguard for a driver and passengers, but for everyone present and involved.
2. In the case of an accident, the judge or management may require a safety inspection of the vehicle and/or harness involved before allowing either to be used in succeeding classes.
3. It is the responsibility of each driver to ensure the harness and cart are in good repair and structurally sound.
4. Drivers should strive to maintain a safe distance from other carts both during the competition and in the warm up and parking areas.
5. All rules of the road should be observed unless a ring steward directs otherwise.
6. Bridles should be adjusted to fit snugly to prevent catching on a cart or other pieces of harness and under no conditions shall a bridle be removed from a horse while it is still put to a cart. Failure to comply will incur elimination.
7. The horse must never be left unattended while put to a cart. Failure to comply will result in elimination.
8. At the discretion of the competition management one header per driver may be utilized to ensure the safety of the exhibitors and spectators. Headers must be properly attired wearing a white lab coat.
9. Junior drivers must have a header. Headers will ride with the driver during the work portion and position themselves at the horse's head in the lineup. Headers should stand at the front and to the left of the horse's head. Headers are to stand still and not touch or interfere with the horse unless it becomes necessary to restrain the horse for safety reasons. If restraint is required prior to the completion of judging, the entry may be penalized.

10. The SHF encourages the use of protective headgear. All Juniors must wear a safety approved helmet while participating in any event sanctioned by the SHF.

## **Style of Driving**

The driver should be seated comfortably on the box so as to be relaxed and effective. The elbows and arms should be close to the body with an allowing, but steady hand enabling a consistent 'feel' with the horse's mouth.

Either the one or two hand method of driving is acceptable. Drivers should not be penalized or rewarded for using one style over another. In a reinsmanship class, in order to evaluate a driver's versatility, the judge may request an appropriate test involving driving with one hand.

## **Use of Whip**

An appropriate driving whip shall be carried in hand at all times while driving. Failure to carry a whip in hand will incur penalties. The whip salute is used to acknowledge the judge at the start and finish of an individual test.

## **Outside Assistance**

Only the driver may handle the reins, whip, or brake during a competition; failure to comply will incur elimination. Drivers receiving outside assistance after the judging has begun will be eliminated at the judge's discretion, unless that assistance has been specifically allowed.

No change of driver is permitted.

## **Dress**

1. Drivers should be dressed conservatively according to the style of the present day. Period costumes or gaudy trappings are discouraged.
2. Dress for the driver should conform to the type of turnout.
3. Gentlemen must wear a coat or jacket while appearing in any class unless excused from doing so by the judge and/or show management. When accepting awards, gentlemen are requested to remove their hats.
4. Ladies must wear a conservative dress, tailored suit, or slacks. Floppy hats are discouraged.

5. Unless otherwise specified, the driver shall wear a hat and gloves.

## The Horse

1. A horse may be of any breed or type, color or size as long as it is capable of performing the gaits required.
2. Braiding of the mane is optional.
3. If shod, it should be suitable for pleasure driving.
4. Snaffle and other types of traditional driving bits are allowed. Burr, gag and twisted wire bits of any type are not permitted.

## Gaits

1. **Walk:** A free, regular and unconstrained walk of moderate extension is required. The horses should walk energetically, but calmly, with even and determined pace.
2. **Slow Trot:** The horse should maintain forward impulsion while showing submission to the bit. The trot is slower and more collected, but not to the degree required in the dressage collected trot. However, the horse should indicate willingness to be driven on the bit while maintaining a steady cadence.
3. **Working Trot:** This is the pace between the strong and the slow trot and more round than the strong trot. The horses go forward freely and straight, engaging the hind legs with good hock action; on a taut, but light, rein; the position being balanced and unconstrained. The steps should be even. The hind feet touch the ground in the foot prints of the fore feet.
4. **Strong Trot (Trot On):** This is a clear, but not excessive, increase in pace and lengthening of stride while remaining well balanced and showing appropriate lateral flexion on turns. Light contact to be maintained. Excessive speed will be penalized.
5. **Halt:** Horses and carts should be brought to a complete square stop without abruptness or veering. At the halt, horses should stand attentive, motionless and straight with the weight evenly distributed over all four legs and be ready to move off at the slightest indication from the driver.
6. **Rein Back:** A backward movement in which the legs are raised and set down simultaneously in diagonal pairs with the hind legs remaining well in line. The horse must move backward at least four steps

in an unhurried manner with head flexed and straight, pushing the carriage back evenly in a straight line, and move forward willingly to former position using the same quiet aids.

## **Turnout Class**

1. A pleasure driving class where entries are judged primarily on the performance and quality of each turnout.
2. To be shown both ways of the arena at a walk, slow trot, working trot, and strong trot. To stand quietly and to rein back.
3. Entries may be chosen for a workout and are to be worked both ways of the arena at any gait requested by the judge and may be asked to execute a figure eight and/or perform other appropriate tests.
4. To be judged 70% on the condition fit and appropriateness of harness/cart; 30% on performance, manners and way of going.

## **Working Class**

1. A pleasure driving class in which entries are judged primarily on the suitability of the horse to provide a pleasant drive.
2. To be shown both ways of the arena at a walk, slow trot, working trot and strong trot. To stand quietly, both on the rail and while lined up, and to rein back.
3. All entries chosen for a workout may be worked both ways of the arena at any gait requested by the judge and may be asked to execute a figure eight.
4. To be judged 70% on performance, manners and way of going of the horse; 20% on the condition and fit of harness and cart; 10% on neatness of attire.

## **Reinsmanship**

1. A Pleasure driving class in which entries are judged on the ability and skill of the driver.
2. Either one or two-handed method of driving is acceptable.
3. To be judged 75% on drivers handling of the reins and whip, his/her control, posture and overall appearance; 25% on the condition of the harness, cart, and neatness of attire.

# **Junior Horse Pleasure Classes**

## **Junior Horse Western Pleasure**

1. This class is open to any horse five years of age or younger.
2. The horse is to be shown in regular Western tack. A snaffle or bosal is preferred but any legal western bit may be used. In a snaffle or bosal, two hands on the reins may be used.
3. Junior horses will not be asked to extend their gaits.
4. The class will be judged and scored under the same criteria as a Western Pleasure class.
5. Points earned in this class count toward a Junior Horse award only.

## **Junior Horse English Pleasure**

1. This class is open to any horse five years of age or younger.
2. The horse is to be shown in regular English tack. A junior horse should be shown in a regular snaffle bit.
3. Junior horses will be shown at a walk, trot and canter, not to gallop.
4. The class will be judged and scored under the same criteria as an English Pleasure class.
5. Points earned in this class count toward a Junior Horse award only.

# **Miscellaneous Classes**

*The following classes are single events only and their points are not considered in calculations for Heritage Circuit awards.*

## **Command Class**

### **General**

The command class is neither a race nor is it a gymkhana event. It is a competition which exhibits the abilities of a well-trained and responsive performance horse.

Riders must be neatly dressed in suitable western or English attire.

# Conduct

1. Entries are eliminated one at a time, at the discretion of the judge as commands are not executed correctly. At no time are horses to be judged individually or one at a time to decide the class. At no time are ring stewards allowed to partake in the judging or placings of the class.
2. The command to stop from the lope or hand gallop can be given only once in each direction.
3. Suggested commands are as follows:
  - Stop
  - Walk
  - Jog
  - Lope
  - Reverse (at any gait)
  - Back up
  - 360 turn on the haunches
  - 180 turn on the forehand
  - Side pass (left and right)
  - Counter canter
  - Dismount
  - Mount
  - Flying change of leads (no more than 8 horses)
  - Reverse simple change of leads (no more than 8 horses)
  - Roll back
4. Examples of elimination are as follows:
  - Failure to execute the command correctly
  - Wrong leads
  - Disunited
  - Excessive speed
  - Breaking gait
  - Hanging up or turning sideways at the back up
  - Circling for better position without being commanded to do so
  - Moving when stopped
  - Moving when mounting or dismounting
  - At the judge's discretion, entries may be eliminated for poor execution of the command, e.g., taking too long to execute transition from one gait to another, horse opening mouth excessively at the back up, etc.

# Hunter Hack

---

## General

The purpose of hunter hack is to give horses an opportunity to show their expertise over low fences and on the flat. The class will be judged on style over fences, even hunting pace, flat work, manners and way of going.

## Conduct

1. The hunter hack horse should move in the same style as a working hunter. The poll should be level with, or slightly above the withers, to allow proper impulsion behind. The head should not be carried behind the vertical, giving the appearance of intimidation, or be excessively nosed out, giving a resistant appearance.
2. Horses may be asked to jump one or two vertical fences not exceeding 2'6". Oxers should not be used. Hunter Hack fences should not be used as a combination. A ground line is recommended for each jump. The two fences may be either a single line, related distance, or two single fences, with an unrelated distance (i.e., not in a straight line).
3. Horses being considered for an award are then to be shown at a walk, trot and canter both ways of the ring with light contact. Horses may be asked to hand gallop but never more than eight at one time.
4. At the discretion of the judge, contestants may be asked to hand gallop, pull up or back and stand quietly following the last fence.
5. Placing for the class shall be determined by allowing a minimum of 70% for individual fence work and a maximum of 30% for work on the flat.
6. Faults over fences will be scored as in working hunter class. Horses eliminated in over fence portion of the class shall be disqualified.

<b>When you Know</b>	<b>Multiply By</b>	<b>To Find</b>
Inches	2.54	Centimeters
Centimeters	0.39	Inches
Meters	3.3	Feet
Feet	0.3	Meters

2'3"	0.70 m
2'6"	0.75 m
2'9"	0.85 m
3'0"	0.90 m
3'3"	1.00 m
3'6"	1.10 m
3'9"	1.15 m
4'0"	1.20 m
4'3"	1.25 m
4'6"	1.30 m





**Saskatchewan**  
Horse Federation

2024

# Prairie Cup Handbook



Revised January 2024

See [saskhorse.ca](http://saskhorse.ca) for Changes Visible Version

Saskatchewan Horse Federation  
300-1734 Elphinstone Street  
Regina, SK S4T 1K1

Phone 306-780-9490

Fax 306-525-4041

Web [saskhorse.ca](http://saskhorse.ca)



# **Prairie Cup - Table of Contents**

Our Mission .....	132
Aims, Goals & Objectives .....	134
Structure & Committee.....	134
Animal Welfare.....	136
Guidelines for Show Committees.....	138
Administrative Rules.....	140
Safety & Risk Management.....	143
Protests / Complaints.....	146
Officials.....	147
Prairie Cup Divisions .....	149
Prairie Cup Awards.....	150
Point Tabulation & Qualifying Rules.....	151
Dressage Division .....	154
Hunter Division .....	159
Hunter Under Saddle Class.....	166
Miscellaneous Hunter Classes.....	167
Jumper Division.....	170
Reining Division .....	181

# Our Mission

---

The Saskatchewan Horse Federation delivers value to its members through initiatives in sport, industry, and other equine activities, while upholding standards of equine welfare.

## A Statement of Principle on Equine Welfare

The Saskatchewan Horse Federation is the voice and leader in an evolving and sustainable horse industry.

We believe it is the responsibility of the Saskatchewan Horse Federation to set provincial standards for competition that are consistent with federal regulations and that bear the welfare of the horse as a primary concern. **Ethics, fair play, and good sportsmanship form the foundation for all activities that pertain to horse events under the jurisdiction of the SHF.**

**The Saskatchewan Horse Federation (SHF), acting as the accepted Provincial Association for provincial horse groups, supports adherence to humane treatment of horses in all activities under its jurisdiction.**

The standards by which conduct, or treatment will be measured is that which a reasonable person, informed and experienced in generally accepted practices, would determine to be neither cruel nor abusive nor inhumane.

For more information on the code of practice visit <https://www.nfacc.ca/codes-of-practice/equine>

## The Saskatchewan Horse Federation will:

- Uphold the welfare of horses, regardless of value, as a primary consideration in all activities.
- Require that horses be treated with kindness, respect, receive good care, and not be subjected to mistreatment.
- Ensure owners, trainers, exhibitors and their agents use responsible care in the handling, treatment, and transportation of horses that are under their care.
- Provide the availability for routine inspection and consultation with health care professionals and industry officials to achieve high practices of nutrition, health, comfort, sanitation, transportation, and safety as provincial standards.

- Support and promote scientific studies on equine health and welfare.
- Offer education in training and horsemanship practices.
- Require owners, trainers, handlers, and exhibitors to know and follow sanctioned rules and regulations and to work within industry standards for equine activities and businesses.
- Review, revise, and develop competition rules and regulations that protect the welfare of horses.

## **Medications Control**

The Saskatchewan Horse Federation reserves the right to introduce drug testing at Heritage Circuit shows in the future. Our intention would be to provide due notice of at least one year to any participating competition and to the membership. However, we are subject to changes in national rules that may not provide for a lengthy notice.

## **Equine Infectious Anemia (EIA)**

**The Saskatchewan Horse Federation strongly recommends that all Prairie Cup competitions require horses to be tested for EIA. All requirements for testing will follow CFIA\* guidelines.**

\*The Canadian Food Inspection Agency is the regulatory body responsible for disease management in Canada.



# **SASK LOTTERIES**

# Prairie Cup

## **Aims, Goals & Objectives**

1. Allow athletes to grow their riding skills while competing in Saskatchewan, and to prepare them to compete at higher levels of competition outside the province.
2. Prepare our equestrian athletes to represent Saskatchewan at Provincial Championships.
3. Promote high performance and work to provide a competition development pathway where athletes can transition from the Heritage program into higher levels of competition. Prairie Cup Competitions include the disciplines of Dressage, Hunter, Jumper and Reining.
4. Raise public awareness of high-performance horse events in the province.
5. Increase participation in equestrian activity.
6. Promote the standardization of rules and regulations of competition that are consistent with national standards.
7. Identify and support riders/athletes who have been successful in their bid to attain the higher levels in their particular equestrian disciplines.
8. Acknowledge successful Prairie Cup athletes as Provincial Champions and have opportunities for them to represent Saskatchewan at Provincial, Regional and Canadian Championships.
9. Partner with Prairie Cup athletes, coaches, officials and show committees to tailor a model for Long Term Equestrian Development that aligns with the National standards and allows our riders the best opportunities for success and longevity throughout their sport life.

## **Structure & Committee**

### **Structure**

The Prairie Cup Committee is an operational committee of the SHF. The Committee reports to the VP of Sport, Board of Directors, and the Executive Director of the SHF.

## **Prairie Cup Committee Chair**

Appointed by the President and approved by the Board of Directors of the Saskatchewan Horse Federation.

## **Prairie Cup Committee Members**

1. The Prairie Cup Committee will work with the Heritage Circuit Committee to ensure seamless transition between the competition levels.
2. The President of the Saskatchewan Horse Federation is an ex-officio member of all SHF committees.
3. The VP of Finance shall serve in an advisory capacity.
4. The Executive Director and Competition Staff Liaison are also members of this committee and serve in an advisory capacity on all matters pertaining to operational aspects of the Prairie Cup Series.
5. Voting representatives on the committee and approved by the Board, should include representation from:
  - a. High performance sport disciplines
  - b. The SHF Coaching Committee
  - c. The SHF Officials Committee

## **Prairie Cup Committee Duties**

1. Update the Prairie Cup Handbook annually as required, keeping it consistent with the Rules and Regulations under which the Prairie Cup Series will operate.
2. Work with the SHF staff to review the show package that is sent to the show committees each year.
3. Assist the office in tabulating points and records of placings used for awarding yearly honors with the Prairie Cup Series and calculating year end awards.
4. Assist in securing sponsorships, donations, and prizes to be awarded to Prairie Cup winners each year.
5. Promote and encourage SHF members to nominate to the Prairie Cup Series.
6. Assist the SHF office staff with preparation of interim reports.
7. Assist the SHF office staff with preparation of an annual report for presentation to the SHF membership at the AGM.

8. Record minutes and motions of all committee meetings and submit to the office of the SHF.

**Any recommendations for policy and program changes to the Prairie Cup Series must be presented to the Board of Directors for approval prior to implementation.**

**Any major changes in the format of the Prairie Cup Series must receive the approval of the Board of Directors of the Saskatchewan Horse Federation prior to implementation.**

## **Animal Welfare**

---

The Saskatchewan Horse Federation is dedicated to the humane treatment and welfare of horses. Cruel, abusive, or inhumane treatment of a horse at any SHF competition by an exhibitor, owner, coach/trainer, or other person must not be tolerated anywhere on the grounds under any circumstances. The SHF supports any decision of officials or show committees that removes a horse from a competition due to obvious lameness or exhaustion.

Cruelty can be defined as causing pain or unnecessary discomfort to a horse, whether intentional or unintentional. The standard by which such conduct or treatment will be measured is that which a reasonable person, informed and experienced in generally accepted equine training and exhibition procedures, would determine to be cruel, excessive, or inhumane. The exhibiting of a horse in an excessive number of classes during a competition is discouraged and may be deemed as inhumane. For Hunter & Jumper classes, the SHF strongly recommends that as the jumping effort increases with height, that riders reduce their number of rounds accordingly.

The organizing show committee must bar such violators from further participation in the competition. It is recommended every horse show publish a statement in its prize list regarding its position on the abuse of horses and its commitment to the humane treatment and welfare of horses, with the penalties to be imposed for confirmed abuse of horses at the show.

In any performance event, the judge shall have the authority to request the removal or alteration of any piece of equipment which, in his/her opinion, would give the horse an unfair advantage or which he believes to be inhumane.

# Important Rules Regarding Equine Welfare

**Dressage Divisions:** A horse/rider may compete in any two, but only two consecutive levels, and a horse may compete in a maximum of four tests per day (combined English and Western), including the Freestyle. It is the Rider's responsibility to make sure that they do not exceed the allowed number of tests per day or year end points may be forfeited in excess of allowance.

**Hunter and Jumper Divisions:** A horse/rider may compete in any three, but only three consecutive class heights, and a horse may jump a maximum of four over-fence classes per day (combined Hunter and Jumper), including specials, classics, derbies, stakes, medals, or equitation over fences. It is the Rider's responsibility to make sure that they do not exceed the allowed number of over-fence classes per day or year-end points may be forfeited in excess of allowance.

**Individual Work:** An exhibitor may ride up to a maximum of three different horses in any one class requiring individual work. A horse can only compete once in any particular class and cannot be ridden by more than one rider.

## Lameness

1. Obvious lameness in any class or event may be cause for disqualification. The following signs will constitute lameness:
  - Marked head bobbing or nodding at the trot
  - Hitching
  - Shortened stride
  - Minimal weight bearing in motion
  - Inability to move
2. In the event that a horse exhibits one or more of these signs, the judge may choose from the following:
  - To not consider a lame horse for placing
  - To give a lame horse a zero or 'no' score
  - To ask that the horse be excused from a class
3. Horses entered in all events must be in good condition. Horses giving the appearance of being emaciated, sullen, dull, lethargic, or showing recent signs of physical abuse or exhaustion may not be placed in a class. At the Judge's discretion, these cases may be dismissed or disqualified for the remainder of the competition day.

# Guidelines for Show Committees

The Prairie Cup Series is a Provincial circuit. Show committees are required to administer their licensed competitions in accordance with the Aims, Goals, and Objectives of the Prairie Cup, with specific attention to ensuring standards of fair play, safety, and equine health and welfare.

1. Prize lists should indicate that their competition is licensed with the SHF and designated as a Prairie Cup approved event (or dual sanctioned)
2. Prize lists are to include information regarding competition licensing and the nominating process.
3. Classes approved for points should be designated on all advertised prize lists.
4. At least one member of the show committee **MUST** be a current SHF individual member for liability insurance reasons. Shows failing to comply will not be recognized as a Prairie Cup approved competition.
5. Each show will receive Prairie Cup first place ribbons for each Prairie Cup class held at their show.
6. Each show will receive a Show License Certificate that must be displayed at the horse show office.
7. Results forms are supplied to the Show Committee secretary and are to be completed for each Prairie Cup class. They must list the placings of all horses from first through eighth place, whether a Prairie Cup nominated horse or not. Accuracy in reporting results ensures provincial championships are calculated correctly.
8. **Membership:** The SHF strongly recommends all shows ensure competitors are either an SHF Individual Member, or if not from Saskatchewan an Individual Member of their Provincial sport governing body (PTSO) affiliated with Equestrian Canada, or they have their own personal liability insurance. This ensures that each competitor has their own personal liability insurance.
9. **Nomination:** Prairie Cup Shows are encouraged to promote nomination of the rider/horse to the Prairie Cup Series, so they will be eligible for year-end awards.
10. **Mentorship Award:** Show Committees are encouraged to solicit and submit nominations for a person who demonstrates the qualities of a mentor. The name of this person should be submitted to the SHF office by the show committee.

11. Show Committees should ensure that all equipment used in the show rings and warm up areas are in good repair and meets required standards. For details on specific class requirements refer to the Division/Class rules. Show equipment should be inspected and in place prior to the start of the show.
12. It is recommended that a full list of equipment be made available to officials prior to the show.
13. Show Committees should have basic equipment available such as a tape measure, rake, stopwatches, numbers, flags, etc.
14. Shows failing to comply with the above will not receive first place ribbons and will not be recognized as a Prairie Cup Series Show.
15. At the discretion of individual show committees, any competitor that is deemed 'not in good standing' by that particular competition organizer, may be denied entry, or refused prizes as set by that competition.
16. Competition organizers are encouraged to also make their events eligible for other programs and incentives (such as NAERIC, PAC and TIPS). Contact the SHF office for more details.
17. It is strongly recommended that competition managers, committee members, and members of their immediate families who compete at competitions they are managing, each declare a conflict of interest and should not be directly involved in paying officials. Declaration of conflict of interest forms are available at the SHF office.
18. The SHF recommends that at least one member of a Competition Organizing Committee has taken Respect In Sport, an online module available through Sask Sport to everyone, free of charge.  
<http://www.sasksport.sk.ca/RiS/>

# Administrative Rules

1. **Handbook: For the current rules of competition and administration, the online version will supersede all printed copies of the handbook.** For the purposes of point tabulation, the competition year for both the Heritage Circuit and Prairie Cup Series will be from November 1st of the previous year to October 31st of the current calendar year.
2. The SHF will supply a first-place ribbon for each Prairie Cup class in all shows participating in the SHF Prairie Cup Series. Ribbons will only be provided for SHF Prairie Cup classes on the approved class list of the current year.
3. **Show Committees must submit applications and FINAL COPY prize lists at least FOUR WEEKS prior to the show date, or a \$25.00 penalty fee may be assessed to the show. Shows submitting late applications must also pay any courier, bus, or extra shipping costs incurred.**
4. Shows are able to dual sanction their horse show to offer both Prairie Cup and Heritage classes. This allows riders to easily make the transition to the higher performance levels.
5. Forms for class results and ribbons will be sent to each show after the SHF office receives and approves their permit, sanction, class applications, and prize list.
6. **The Show organizers must submit the results of each SHF Prairie Cup class along with any nominations or membership applications received at the show. All show organizers must submit the \$50.00 filing fee, or their show will not be sanctioned.** The show organizer can submit a separate cheque for the \$50.00 filing fee which will be destroyed if results are received in the SHF office within 2 weeks from the last day of the show OR the show organizer can pay the \$50.00 filing fee along with all other show permit/sanctioning fees (by e-transfer or credit card) and a refund will be issued if show results are received in the SHF office within 2 weeks from the last day of the show.
7. **Dressage placings AND percentage scores MUST be submitted to the SHF by show committees on the results forms.**
8. **Reining placings AND scores MUST be submitted to the SHF by show committees on the results forms.**

9. Competition results must be received by October 31st for points to be included in the tabulation for awards.
10. Horses Nominated for the Prairie Cup Series will begin point accumulation only AFTER the horse/rider combination is nominated. Shows entered prior to nomination of horse/rider WILL NOT be considered.
11. Persons may nominate their horse at a show on the form provided. To be eligible for awards, a person must be a current Individual Member of the SHF and nominate the horse on which s/he wishes to accumulate points.
12. Riders are able to nominate to both Prairie Cup and Heritage Circuit (dual nominate) and will collect points in each respective circuit.
13. The show must forward all membership applications and nominations it receives to the SHF promptly, to ensure competitors receive their proper points.
14. Once a class has begun (the gate shut, or the first horse judged) no further entries will be accepted at the show office or at the gate.

**15. Dressage Division:**

- a. **A horse/rider may compete in any two, but only two consecutive levels, and a horse may compete in a maximum of four tests per day (combined English and Western Dressage), including the Freestyle.**
- b. When there is only one horse in a class, ribbons and prizes shall be awarded in accordance with the following percentages:

1st	63% or higher
2nd	60% to 62.9%
3rd	58% to 59.9%
4th	51% to 53.9%
No ribbons or prizes shall be awarded below 3rd position.	

## 16. Hunter/Jumper Divisions:

- a. A horse/rider combination may compete in a maximum of three consecutive heights per day.
- b. A horse may compete in a maximum of four over fences classes per day which applies to combined Hunter and Jumper classes including specials, classics, derbies, stakes, medals, or equitation over fence (not including Hunter warm ups, Jumper clear-rounds and hors concours rounds). Hunter classics and hunter specials that are 2 round classes will count as one over fences class. Jumper classes that include a jump off will count as one over fences class.
- c. Hors concours rounds are allowed at the discretion of the judge and/or show committee. Hors concours riders will pay a regular entry fee and will follow all rules pertaining to the competition. They will not be eligible for awards. A horse or pony that has competed "HORS CONCOURS" is not permitted to be judged in the same ring on the same day. A horse or pony may only compete "HORS CONCOURS" once in the same ring on the same day.
- d. A horse is limited to one round per class and may not be ridden by more than one rider in that class.
- e. An exhibitor may ride up to three different horses in any one class.

## Age Categories

1. Prairie Cup riders competing in Hunters, Jumpers, and Dressage will adhere to the following age groups:
  - a. Age is determined by the year of birth as it appears on their birth certificate. A participant is considered to be a certain age until the end of the calendar year in which he or she turns that age. So, a rider would remain a Junior until the end of the calendar year in which they turn 18.

Junior	17 years and under (Born 2006 or later)
Senior	18 years and over (Born 2005 or earlier)

2. Prairie Cup Reining will follow NRHA designations of Open, Non-Pro and Youth.

# **Safety & Risk Management**

The Saskatchewan Horse Federation urges all members to develop a Safety Awareness Program for each of its events for the benefit of the participants, the spectators and the event management involved. The staging of Horse Shows is an activity that is particularly vulnerable to accidents, and therefore the Show Committee has a special responsibility to provide an event that is run as safely as possible.

**No toddlers, or infants (in strollers, snugly, or carried) are allowed in the warm up rings.**

## **Safety Committee**

It is a requirement for insurance purposes that all Horse Show Committees have a safety sub-committee that has the authority to develop safety policies and procedures for their event and to enforce those regulations. The Show Committee should:

1. Name a chairperson who is responsible for Safety Precautions during the event.
2. Have the Safety Committee develop, and the Horse Show Committee approve, the safety guidelines for the event. Include development of a Crisis Plan to address unforeseen occurrences such as protocol in the event of severe inclement weather, or an attendee or guest threatening harm to horses and/or riders.
3. Empower the Safety Committee to enforce any rules or regulations relating to the safety guidelines during the event.
4. Record and report to the SHF any untoward incidents or accidents that occur during the staging of the sanctioned event.
5. Record keeping: Accurate records of the event, and any other matters that require documentation, should be kept by the show secretary for not less than two and a half years following the event.
6. Ensure emergency medical attention is available for every event.
7. An Emergency Action Plan should be made available to all officials.

## Liability Waiver

It is recommended all horse shows use an Acknowledgment of Risk and Release of Liability form to be signed by each participant at the event. Do not be deterred by the criticism that waivers 'do not hold up in court' or 'are not worth the paper they're written on'. Every piece of documentation counts when a legal claim is instituted. **It is especially important that you verify that parents/guardians have signed the Acknowledgment of Release form for anyone under the age of 18 years.**

Should people refuse to sign the form, the show committee can refuse to allow them to participate in the event. However, do not coerce persons into signing the waiver. It must be their decision. If they wish to participate in the event, a waiver is a part of the agreement they must undertake.

A sample form is available for use by shows. The Saskatchewan Horse Federation does not make any claims as to the effectiveness of the form. Every show is advised to consult a lawyer regarding a suitable form for use at their event.

## First Aid & Emergency Medical Help

1. It is essential that every horse show has a plan in place for emergency medical help.
2. A show should have a First Aid Kit readily available at all times for minor incidents. The kit should include a St. John's First Aid Emergency Medical Help reference handbook or similar publication for consultation.
3. A show should have, preferably on hand during the entire event, a person(s) who is trained and knowledgeable in First Aid/Emergency Medical Treatment. Depending on the risk involvement of the particular sport and the availability of medical help, such a person might be a First Responder, a Certified Coach, a registered nurse, an EMT, a Ski Patrol official, or similar other person who has some first aid designation.

- a. **Ambulance/MD:** If they are not present at the event, ensure the contact information for either or both is readily available in case of emergency. It is advisable to contact them in advance with details of your event in case their services are required.
- b. For specific safety and medical services required for Hunter Over Fences and Jumper classes, see pages 160 for Hunter & 171 for Jumper.
4. A backboard and collar are advisable to have on hand at all show events but must only be used by trained personnel.
5. If a person is rendered unconscious or complaining of back pain, under no circumstances should that person be moved. Wait until qualified medical help is present before moving such a person.
6. If a show is sanctioned under Equestrian Canada rules, the EC Accidents & Return-to-Play Rule is in effect. For more information see [equestrian.ca](http://equestrian.ca) or the Equestrian Canada Rulebook, Section A, General Regulations, Article 101.

## Safety Checklist

1. Make a safety checklist for your show, with a plan of action to ensure safety procedures are followed. Some areas to include:
  - a. Stable and arena safety, warm-up and competition rings
  - b. Spectator areas, seating, parking and walkways
  - c. Emergency Action Plan
  - d. Fire precautions, emergency measures and emergency exits
  - e. Contact information for suggested veterinarians and farriers
  - f. Availability of an AED device
2. **Signage:** Post all Emergency Rules and Regulations that participants and spectators are to follow. Use signage to alert persons of any dangers. Be sure to post rules and guidelines for the safety and protection of all youth and vulnerable individuals on the premises, both as participants and as spectators.
3. Other policies to consider:
  - a. Unruly horses and/or people
  - b. Alcohol/drugs and their use while on the premises
  - c. Smoking and its non-use in areas such as arenas, stables, etc.
  - d. Dogs/pets running at large
  - e. Children unattended

- f. Visitor/spectators in horse areas
- g. Garbage disposal
- h. Use of protective headgear, etc.
- i. Any other areas of concern specific to the individual event that may exist. Identify them and have a plan to deal with them.

## Biosecurity

All show committees should follow general Equine Health and Welfare guidelines. Contact the SHF office for more information.

## Accident/Untoward Incident Report Form

1. Prepare a form and record any accident/incident that occurs at the event no matter how trivial it may seem at the time. The incident may involve any person or horse on the competition grounds. A sample form is included from the SHF for your consideration.
2. Have the report form signed, dated, and if possible signed by any relevant witnesses to the accident/incident. Make sure the report form answers the six big questions: WHO, WHAT, WHEN, WHERE, HOW, and WHY.
3. Describe the conditions present at the time, e.g. weather, crowds, outside interferences, etc. While such reports may seem unnecessary at the time, this record could be an invaluable aid should questions arise at a later date, especially in the event of any legal action.
4. A copy of the completed form should be forwarded to the SHF office with competition results.

**Remember: Legal action may be instituted up to two years or more following an incident. Therefore, it is essential to keep all records pertaining to the show, so that they can be accessed if needed at a later date.**

## Protests / Complaints

---

1. For protests regarding decisions of the competition official arising from the field of play (including decisions based on a factual observation of the performance during a competition or the awarding of marks for performance such as scores or placings):
  - a. The protest must be made in writing. It must be submitted, along with \$25.00 cheque payable to the Show Committee, within **one hour** of the statement of an alleged violation of a rule or condition of a class. In the case of an infraction involving another

competitor, you must provide the name or competitor number of the alleged violator.

- b. The Show Committee (and the competition official, if they so choose) will review the protest and determine a ruling based on the rules and regulations under which the show is sanctioned.
  - c. Once a final decision has been reached by the Show Committee there will be no further protest.
  - d. Protest fees will be returned only if the ruling is made in favour of the complainant. This procedure will take precedence over all other protest procedures.
2. For protests regarding an infraction to the SHF Code of Conduct:
- a. This would fall under the SHF Discipline and Complaints Policy and should be referred to the SHF Office for the formal Dispute and Resolution process. For more details see [www.saskhorse.ca](http://www.saskhorse.ca) or contact the SHF Office.

## Officials

---

**Prairie Cup Dressage** competition requires the use of Equestrian Canada dressage officials or SHF officials having a minimum of provincial senior dressage status.

**Prairie Cup Hunter/Jumper** competitions requires the use of Equestrian Canada officials or SHF officials having a minimum of provincial senior hack/hunter/jumper status. All competitions offering over fences classes at the Prairie Cup level (2'9" hunters & above) and **ALL** jumpers requires the use of an Equestrian Canada or USEF approved course designer. **This is to ensure required standards of safety, fair play, and equine welfare are met.**

**Prairie Cup Reining** competitions requires the use of NRHA officials.

A current list of officials is available through the SHF. Information on guest carding can be obtained by contacting the SHF office.

Before selecting your officials, please consider the following conflict of interest situations:

1. Judges shall not officiate in any division in which a member of their family or a horse owned by the immediate family is competing, or in which clients and/or their horses are competing.
2. No judge who owns or is employed at an establishment may judge any horse or competitor that boards, is trained, or takes instruction

at said establishment.

3. A judge may not judge any division where a competitor or exhibitor is the owner or employee of an establishment at which said judge boards, trains, or takes instruction.
4. Judges may not discuss the purchase, sale, or lease of any horse for the duration of a competition at which they are officiating.
5. Judges may not be the house guests of any person, or immediate family member of a person, who is competing in the event at which they are judging. This applies for a period from the day preceding to the completion of the event.
6. Neither Competition Managers nor members of their immediate families are eligible to serve in any position where they receive remuneration (such as judge, steward, course designer, or technical delegate) at any competition they are managing.
7. It is strongly recommended that Competition Managers, committee members, and members of their immediate families who compete at competitions they are managing, each declare a conflict of interest and should not be directly involved in paying officials. Declaration of conflict of interest forms are available at the SHF office.
8. Course Designers may not compete over any course which they have constructed or designed.
9. Ring Masters shall not officiate in any divisions of a competition in which they or any member of their immediate family or any of their clients are exhibitors.
10. No horse may be shown to a judge if that judge has owned, trained or acted as an agent within the previous four months prior to the competition, excepting a judge that a competition has had to substitute due to circumstances beyond their control.
11. No horse may be shown to a judge that has been leased or owned by that judge within the four months prior to the start of the competition.

# Prairie Cup Divisions

---

Prairie Cup recognized classes shall be assigned to one of five divisions.

## Dressage Division

- Second Level: EC Tests 1, 2, 3, Freestyle
- Third Level: EC Tests 1, 2, 3, Freestyle
- Fourth Level: EC Tests 1, 2, 3, Freestyle
- Advanced: FEI Prix St. Georges/Intermediate 1, Grand Prix/Grand Prix Special

## Hunter Division

- Low Hunter: 2'9"–3'0"
- Medium Hunter: 3'3"–3'6"
- High Hunter: 3'9" and above

## Jumper Division

- Schooling Jumper: 0.75m–0.85m
- Low Jumper: 0.90m–1.05m
- Medium Jumper: 1.10m–1.15m
- High Jumper: 1.20m–1.25m
- Advanced Jumper: 1.30m and above

**All Prairie Cup approved Jumper classes under 0.90m will not be run as Speed classes**

## Pony Jumper Division

- Pony Jumper classes are to run as per the guidelines set by Equestrian Canada.

## Reining Division

- Open (No \$ limit)
- Non-Pro (No \$ limit)
- Youth (18 & under)

**Rookie, Green and Novice classes will not be eligible**

# **Prairie Cup Awards**

---

## **Hunter Division**

Junior and Senior, Champions and Reserve Champions will be awarded in Low Hunter, Medium Hunter, and High Hunter.

## **Jumper Division**

Junior and Senior, Champions and Reserve Champions will be awarded in Schooling Jumper, Low Jumper, Medium Jumper, High Jumper, and Advanced Jumper

## **Dressage Division**

Junior and Senior, Champions and Reserve Champions will be awarded in Second Level Dressage, Third Level Dressage, Fourth Level Dressage, and Advanced Dressage.

## **Reining Division**

Champions and Reserve Champions will be awarded in Open Reining, Non-Pro Reining, and Youth Reining.

## **Mentorship Award**

Awarded to a competitor, coach, parent, or volunteer who has demonstrated, through his/her interactions at a Saskatchewan Horse Federation competition, the qualities of a mentor. This person will have guided, instructed, or led by example, and by so doing, has helped fellow competitors, students, or show committees.

## **Active for Life Award**

Presented annually to recognize competitor(s) over 45 years of age. Awarded to a Heritage Circuit and/or Prairie Cup Series nominated competitor who requests on their nomination form to be considered for this award. The winner(s) will be determined by total points earned in competition.

## Prairie Cup Sask Bred Awards

This award recognizes the unique talents of specialized horses competing at discipline specific events. Total points earned by a Prairie Cup nominated, Sask Bred horse, bred by a certain farm or person, will be counted from each of the four Prairie Cup disciplines (Hunter, Jumper, Dressage and Reining). Horses must have won a Prairie Cup Championship or Reserve Championship. Annual recognition will be awarded to the top breeder in each category.

# Point Tabulation & Qualifying Rules

---

1. A horse and rider must be nominated to the Prairie Cup Series to be eligible for awards. The rider must be a current individual member of the SHF.
2. A horse and rider wishing to be considered for more than one PC discipline must apply and pay for a separate nomination in each discipline.
3. A horse may be nominated by more than one person, but points will be given **per nominated horse/rider combination**. To earn points with a second rider, the horse/rider pair must file and pay for a second nomination in that rider's name. Points are non-transferable.
4. Riders are responsible for completing nomination forms accurately and in entirety. Failure to do so may result in points not counting toward awards.
5. **Nominations must be complete prior to a show for points earned to count.**
6. Riders that have dual nominated and earn points in Equitation classes at SHF licensed competitions will have their points count only towards Heritage Equitation awards.
7. **To be considered for ANY Prairie Cup Series award, a competitor must earn points at a minimum of two competitions and must earn points or scores in a minimum of two classes.**
8. Points will be counted for awards from all Prairie Cup sanctioned events in the province.

9. **Out of Province Competition:** Riders competing outside the province may accumulate points toward Prairie Cup awards if they place in classes that are of equivalent heights to PC Hunters and Jumpers, or of equivalent levels in Dressage and Reining.
  - a. Competitors are eligible to earn points at competitions out of province but cannot earn such points exclusive of participation in SHF competitions. **To be eligible for year end awards, a rider must earn points at a minimum of one Prairie Cup SHF competition in the same discipline they are submitting out of province points for.** In the event that there are no SHF competitions offering a particular PC approved class in that calendar year, a rider may earn points solely in out of province competitions.
  - b. **Out of Province Results:** Riders must voluntarily submit results on the Out of Province Point Form available on the SHF website. **Proof of placing (and score for Dressage and Reining) must be verified by providing official competition results, along with proof of a competitions designation (FEI, Platinum, Gold, Silver and Bronze).** The deadline for submission of out of province points will be October 31 of the competition year.
10. An individual's points will not be released without the written permission from the nominated rider/handler. After all the points are tabulated and awards designated, the points will be official and available to nominated riders.

11. To be declared a **Provincial Dressage Champion** a rider must meet a minimum required score of 60% for champions and 57% for reserve champions in a designated PC level division.
12. To be declared a **Provincial Reining Champion** a rider must meet a minimum required score of 65 in a designated PC division. Winners will be determined by calculating an average of acquired scores.
13. To be declared a **Provincial Hunter Champion** a rider must place a minimum of two times in a PC designated division. Riders must meet minimum requirements of standing ahead of at least 15 horses (for Low Hunters), 10 horses (for Medium Hunters) and 5 horses (for High Hunters).
14. To be declared a **Provincial Jumper Champion** a rider must place a minimum of two times in a PC designated division. Riders must meet minimum requirements of standing ahead of at least 15 horses (for Schooling and Low Jumpers), 10 horses (for Medium Jumpers), and 5 horses (for High and Advanced Jumpers).

# Dressage Division

---

## General

Dressage is an exhibition of riding in which the horse is controlled in certain maneuvers by very slight movement of the rider's hands, legs and weight in the saddle. Horses can be of any breed and size.

Dressage is shown at specific levels. These levels are progressively more difficult and reflect the development of the horse and rider's skills and abilities. The tests ridden in competition measure the horse and rider's schooling and correctness and are scored accordingly. Each level has a specified format which is stated on the test form. Each movement within the test is described and the elements to be performed are outlined.

Prairie Cup Dressage consists of Second Level and above tests.

Horses and riders working at these levels should be proficient in the previous levels. They should be able to do trot work on 10-meter circles and canter work on 15-meter circles. They should be able to demonstrate lengthening of trot (including sitting) and lengthening of canter. Serpentine, leg yielding and change of canter lead are also required movements.

All Prairie Cup sanctioned shows will use Equestrian Canada dressage tests and will follow Equestrian Canada Dressage Rules. Please refer to the EC website for details.

**A horse/rider may compete in any two, but only two consecutive levels, and a horse may compete in a maximum of four tests per day (combined English and Western Dressage), including the Freestyle.**

## Attire

1. In keeping with the tradition and dignity of the sport, manes should be braided, unless roached, and dress and equipment neat and clean.
2. All Junior and Senior Dressage riders, regardless of the level they are competing at, must wear an approved helmet.
3. A dark colored jacket, conservative colored breeches, black or brown boots, tie, hunting stock or choker, and gloves. Juniors are permitted to wear jodhpurs and boots. Spurs are optional.
4. Riders with long hair must wear hair nets or tie hair back in a braid or bun.

5. In the case of inclement weather, competitors may wear a suitable hat cover and a warm or waterproof overcoat. In extreme heat or humidity, the judge may permit competitors to ride without jackets.

## Tack & Equipment

1. A plain English saddle, black or brown color only, with stirrups is compulsory in all levels.
2. All bridles must be English style and correctly fitted, reins must be only black or brown in color. Only snaffle bits are allowed for Second Level. Double bridles may be used in Third Level and up.
3. Type of reins is optional, attachment to the bit may be by buckle, stud or rings, but reins with hand loops, elastic or stretchy rubber inserts or any other attachment are prohibited. Reins must not be made of rope or ropelike material. Reins may be laced, plain, rolled, or rubber lined on one or both sides. Reins may have hand stops.
4. Whips not exceeding 1.2m in length may be used, except at a championship show.
5. Martingales (other than running), bit guards, any kind of gadgets, any form of blinkers, and seat covers, are under penalty of elimination and strictly forbidden on the show grounds at any time during any competition.
6. Ear Hoods are permitted and may also provide noise reduction. However, hoods should be discreet in color and design. Ear Plugs are forbidden.
7. Boots or bandages may not be worn in the competition.
8. Breastplates, foregirths, girth covers, cruppers and non-restrictive nose fly guards are permitted.
9. The use of two-way communication devices in the competition arena is prohibited.

## Scoring

10 – Excellent  
9 – Very Good  
8 – Good  
7 – Fairly Good  
6 – Satisfactory  
5 – Sufficient

4 – Insufficient  
3 – Fairly Bad  
2 – Bad  
1 – Very Bad  
0 – Not Performed  
½ Points may also be awarded

### **The collective marks are based on:**

1. The freedom and regularity of the horse's movement (gaits).
2. The horse's desire to move forward with elasticity of steps and roundness (impulsion).
3. The horse's attention and confidence, harmony with the rider, lightness of movement and acceptance of the bit (submission).
4. The rider's correctness and effectiveness of aids (position and seat).

## **Faults and Eliminations**

### **Riders will incur faults or eliminations for:**

- Disobediences
- Excessive resistance
- Use of illegal equipment
- Inappropriate tack or attire
- Fall of horse or rider during test
- Dangerous or unruly behavior of horse
- All four feet of horse leaving the arena area
- Lameness
- Taking excessive time to enter the arena after the signal. Not entering the arena within 45 seconds after the signal, but within 90 seconds, is considered an error and two points will be deducted. Horse and athlete combinations not entering the competition arena within 90 seconds after the signal will be eliminated
- Evidence of blood on horse
- For a more extensive list of Faults and Eliminations see the Equestrian Canada Rule Book at <https://www.equestrian.ca/programs-services/rules>

## **Arena**

1. The arena must be flat and level, must be predominantly sand footing and must be 20 x 60 meters for the Prairie Cup levels in dressage.
2. The arena should be separated from the public by a distance of 15 meters surrounding the arena if possible.
3. The arena itself should be surrounded by a low fence about 0.30 meters high. The part of the fence at "A" should be easy to remove to allow the competitor in and out of the arena in a suitable way. The rails of the fence should be such to prevent the horse's hooves from entering.

4. The letter markers outside the ring enclosure should be placed about 0.5 meters from the fence and clearly marked. It is desirable to put a special mark on the inside of the fence itself, level with and in addition to the letter concerned. The part of the fence at A can remain open. The letter A must be placed at least 5 meters away from the arena and a distance of up to 15 meters is permitted.
5. Arena fence conditions must be the same for all competitors in a class.
6. The center line, through its length, and the three points D, X and G are desirable (but not mandatory) and must be clearly marked, but not to frighten the horse.
7. The judge must have a separate table that is raised if possible, to give him/her a good view of the arena.

# Dressage Arena

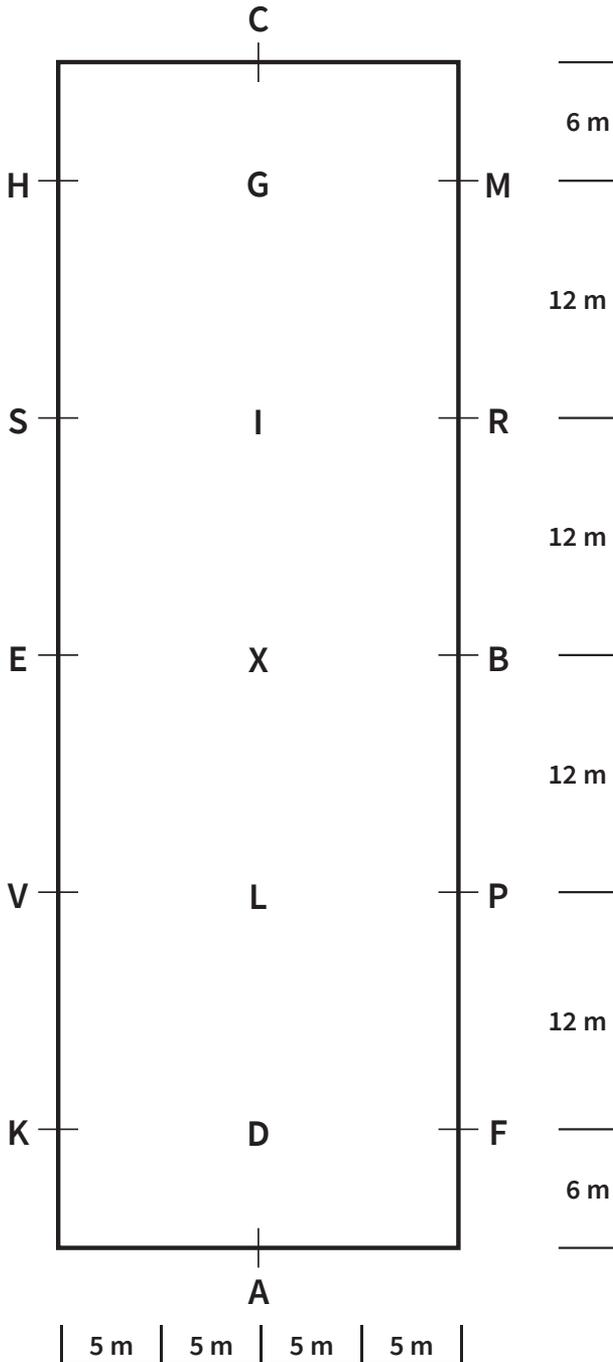

# Hunter Division

---

## General

A hunter should display good jumping form and be calm and confident while doing so. The horse should move with a steady rhythmic canter between the fences and jump the fence in a manner that appears to flow. The pace should be even throughout the course and the horse should adjust its leads accordingly. The horse should meet the fence squarely and jump in the center of the obstacle. A hunter should be relaxed but show a willing and alert attitude. It should remain calm on its approach to the jump and continue on course quietly after landing. A good hunter completes the course with cadence, balance and style in a manner that is comfortable and safe.

**A horse/rider combination may compete in a maximum of three consecutive heights per day.**

**A horse may compete in a maximum of four over fences classes per day which applies to combined Hunter and Jumper classes including specials, classics, derbies, stakes, medals, or equitation over fence (not including Hunter warm ups, Jumper clear-rounds and hors concours rounds). Hunter classics and hunter specials that are 2 round classes will count as one over fences class. Jumper classes that include a jump off will count as one over fences class.**

**“Hors concours” rounds are allowed at the discretion of the judge and/ or show committee. Hors concours riders will pay a regular entry fee and will follow all rules pertaining to the competition. They will not be eligible for awards. A horse or pony that has competed “HORS CONCOURS” is not permitted to be judged in the same ring on the same day. A horse or pony may only compete “HORS CONCOURS” once in the same ring on the same day.**

**A horse is limited to one round per class and may not be ridden by more than one rider in that class.**

**An exhibitor may ride up to three different horses in any one class.**

## Headgear

At competitions offering over fences classes, approved protective headgear (helmet) with safety harness permanently affixed to the helmet is compulsory for everyone riding anywhere on the competition grounds.

It is mandatory that the protective headgear meets the A.S.T.M./SEI standards. At competitions offering hunter classes, anyone mounted on a horse on the competition grounds must wear approved helmets with safety harness correctly fastened, at all times. Protective headgear must be certified under one of the following standards: ASTM (American Society for Testing Materials), SEI (Safety Equipment Institute, Inc.), BSI/BS EN (British Standards Institution), EN (European Union Standards), As/NZS (Australian/New Zealand Standards), or CE VGI 01.040 2014-12.

## **Safety/Medical Services**

It is mandatory that all competitions where persons are required to jump over obstacles have Emergency Medical Service on site. There should be a minimum of advanced first aid and basic cardiac life support (BCLS) provided. The presence of an ambulance is not required. A crisis response plan should be prepared in advance by the Show Committee.

## **Number Rule**

At Prairie Cup (or dual sanctioned Heritage/PC) shows, competitors are required to wear their bridle/back numbers at all times when the horse is being schooled, whether mounted or not.

## **Tack & Equipment**

1. Hunter classes (both under saddle and over fences) have requirements for classic, plain tack that demonstrates that the hunter is easy to ride and attentive and responsive to its rider.
2. The saddle is usually a type of forward seat (jumping saddle), generally of the style called 'close contact'. Saddles are usually of brown leather.
3. Girth should be plain, preferably, leather. Sheepskin on girth is permissible.
4. The saddle pad (numnah) should be white and shaped to fit the saddle.
5. The bridle is simple, with a plain cavesson (any type of noseband other than a plain cavesson is prohibited) and a simple, unadorned browband.
6. Bits are also simple, usually a classic snaffle bit of a dee-ring, egg-butt, or full cheek design. A double bridle, pelham or kimberwick may also be used. Bit converters may only be used in junior and amateur classes, 3' and under. Milder bits are preferred in hunter classes.

7. Martingales either standing or running (with rein stops) may be used in over fences classes. Hunting breastplates are permissible.
8. Bandages and boots are not allowed in hunter rounds but may be used in equitation classes. In inclement weather, bandages or boots may be allowed at the discretion of the judge.
9. Whips cannot exceed 75cm (29.5") and must be un-weighted.
10. The use of earphones or earbuds or other communication devices are strictly prohibited in the competition arena.

## **Attire**

1. The hunt coat should be of traditional style and conservative color (navy, gray, hunter green, or dark brown).
2. Breeches should be light colored.
3. Traditional black boots should be worn but paddock boots (black or brown) may be used with matching smooth leather half chaps (no suede). Younger riders may wear paddock boots with jodhpur pants and straps.
4. The shirt (rat catcher) should be white or a light pastel color.
5. Dark gloves should be worn and are required for equitation classes.
6. Hair must be neat and contained in a net or braid.
7. At the discretion of the judge, mandatory use of hunt coats may be waived if weather is excessively hot and/or humid.
8. No sweatshirts, t-shirts or tank tops are permitted. Shirts must be neatly tucked into breeches.

## **Grooming and Braiding**

1. The hunter horse must be very neat and well presented. They should have their manes (and sometimes tails) braided for showing.
2. If braiding is not possible, the mane is to be neatly pulled to lie flat on the horse's neck.
3. If braiding the tail, it should be braided into a french style braid that runs the length of the tail bone, with the remainder of the tail allowed to flow freely.
4. Horses should have any long body hair trimmed short, particularly around the fetlocks, jaw, muzzle and ears.

# Hunter Courses

1. **The SHF insists on the use of course designers when setting over-fences classes at a Prairie Cup level competition. Please contact the SHF office for more information and a list of approved course designers.**
2. Course Designers are encouraged to build courses that are not overly complicated and that reflect the abilities of the horses and riders at the competition.
3. A hunter course should typically consist of 8–10 obstacles. The course should be simple and inviting and should include verticals, oxers, gates and fences with natural fill such as brush and flowers. Fences should simulate those found in a field, such as natural looking rails, brush, walls and coops. The fences should be natural colors such as brown, green, beige and white. Solid fences with lots of fill and a well-defined ground line are easier to jump.
4. Jumps with spread (oxers) must have the back rail higher than the front. The height of the fences should not exceed that listed for the class. For example, if it is a 2'6" Hunter class, the back rail of the oxer must not exceed that height.
5. **Plastic jump cups and pins must be used.** Breakaway jump cups on tracks may be used. Metal jump cups and/or pins are forbidden.
6. Hunter courses for Prairie Cup classes should use traditional component tracks (or 'lines') of side, diagonal and quarter line wherever possible. A simple bending line or a roll back may be used in an equitation course. Refer to sample course on page 169.
7. Hunter distances are typically based on a 12-foot stride. Adjustments should be made according to the height of the fences being jumped (i.e., slightly lengthen the distances between related obstacles as the height of the fences goes up).
  - a. Adjustments may also be made according to ring size and footing (e.g., depth or weather conditions).
  - b. Slope of the arena and whether or not the fences are set going away from or toward the in-gate may also affect stride length.
8. Horse shows offering over fences classes must provide a safe warm-up area (preferably fenced) with a minimum of one straight (vertical) and one spread (oxer) fence for practice. Flags to indicate direction are required (red flag on right side and white on left).
9. No competitor will be allowed to set or use this equipment outside of the scheduled show or designated schooling times.

10. Shows offering hunter classes are also encouraged to allow time for schooling rounds. The times for rounds will be determined by the show committee and will be dependent on the facility as well as the availability of equipment and emergency medical services.

## **Class Conduct**

1. Hunter courses must be clearly posted a minimum of 30 minutes prior to start of class.
2. Horses are shown, one at a time, over a course of hunter style obstacles.
  - a. At the discretion of the Competition Management, and if course design permits, 'pre-loading' of the hunter ring is permitted. The gate person will control this process.
3. A performance starts when the horse enters the ring and ends when it leaves.
4. Awards will be given once all horses have completed the course.

## **Judging**

A hunter is judged on movement, manners, jumping style/performance and hunting soundness. At the judge's discretion, horses may be asked to jog for soundness.

## **Jumping Style/Performance**

A good show hunter must possess an excellent jumping form. The forearm should be parallel with, or higher than the ground. The knees and lower legs should be even. The horse should not be lazy with its lower legs but tuck them under its forearm as it clears the fence, clearly bending its fetlocks and knees. The horse should not throw its body or legs to one side but should stay perfectly straight over the fence. A good hunter should show a great 'bascule' or roundness, over a jump.

## **Movement**

A good hunter should cover the ground effortlessly with long, low sweeping strides. It should be able to collect and lengthen its stride while maintaining its tempo and rhythm.

It should not have excessive knee action, nor should its strides be short and choppy, both of which would make its movement less efficient.

1. The walk should be free and ground covering.

2. The trot should show balance and cadence and be ground covering without excessive speed
3. The canter should display long, low strides that cover the ground with relaxed, free-flowing movement

## Manners

A hunter should display an alert and willing attitude. It should be relaxed and responsive to invisible signals from its rider and it should present an overall appearance of being easy to ride. The horse should be obedient to light hand and leg cues. Transitions should be smooth and on cue.

## Soundness

A hunter must display hunting soundness and must be free from any sign of lameness.

## Scoring

1. Horses will be credited for maintaining an even hunting pace while covering the ground with free-flowing strides. Preference will be given to horses that meet the fence squarely, at the center of the fence, and jump with correct jumping style.
2. Circling once upon entering the ring and once before leaving is permitted. Horses shall be rewarded for entering and exiting the ring at a relaxed walk.
3. Horses will be penalized for unsafe jumping and bad form, whether or not they touch the fence. Twisting, incorrect leads and cross-cantering will be penalized. Adding a stride between fences of a 'related' distance will be penalized. Leaving out a stride is considered dangerous and will be heavily penalized. Further penalties may be incurred by excessive speed or slowness, breaking gait, opening of the mouth, kicking out, spooking or shying, pinned ears or tail wringing, or swapping leads when not asked for.
4. Excessive use of the whip will result in penalties. A rider may be disqualified for striking a horse more than twice.
5. Refusals and knockdowns will be heavily penalized. An obstacle is considered knocked down when the height is lowered by the horse or rider through contact with the rail or standard.

**Scoring of hunters is based on 1–100. With the following breakdown:**

**90-100:** An excellent performer and a good mover that jumps the entire course with cadence, balance and style.

**80-89:** An excellent performer that commits one or two minor faults: or, a good performer that jumps all fences reasonably well.

**70-79:** A good performer that makes a few minor faults: or an average mover that makes no serious faults but lacks the style and cadence of the scoper horse.

**60-69:** Poor movers that make minor mistakes such as cross canter: or average movers that have no major faults or disobediences but had one or two poor fences.

**50-59:** A horse that commits one major fault, such as refusal, break of gait, drops a leg, showing bad jumping form. Rider touching horse with whip.

**30-49:** A horse that commits two or more major faults, such as knock downs, refusal, dangerous jumping.

**10-29:** A horse that avoids elimination but jumps in a manner that is dangerous.

## **Disobediences**

1. Refusal: When a horse stops in front of an obstacle (whether or not it is knocked down). If the horse is moved toward the obstacle but does not attempt to jump, it is considered another refusal.
2. Run-out: When a horse evades or passes the obstacle to be jumped.
3. Loss of forward movement: When a horse fails to maintain the trot or canter after beginning the course.
4. Unnecessary circling on course: When a rider circles his/her horse in such a manner that its original track between two consecutive obstacles (anywhere on course) is crossed. The exception to this is if the horse is retaking an obstacle after a refusal or run-out.

## **Elimination**

- Two disobediences including refusal, stop, run-out, or extra circle
- Bolting from the arena
- Being off course
- Jumping an obstacle before it is reset
- Fall of horse and/or rider. A horse is considered to have fallen when shoulder and haunch on the same side touch the ground. Rider may not remount

# **Hunter Under Saddle Class**

---

Prairie Cup shows are encouraged to offer proper Hunter divisions and should include a Hunter under Saddle class. To be eligible for show awards, horses must compete and complete the course in at least one over fences class in their respective division. Hunter under saddle classes must never be the first class of a division.

For example, a Hunter Division would consist of:

- 3' Hunter Over Fences Class
- 3' Hunter Under Saddle Class
- 3' Hunter Stake Class

Points earned in Hunter under Saddle classes count for division awards only and are not considered for Prairie Cup Awards.

## **Class Conduct**

Horses from a particular hunter division will show together in the under saddle (flat) portion. They will be shown at a walk, trot and canter, both ways of the ring. At the judge's discretion, they may be asked to gallop (no more than eight horses to hand gallop at one time).

## **Judging**

Horses are to be judged on their performance, condition and conformation. They should possess the same quality of movement as described for a good hunter. A flowing, balanced performance that shows cadence and willingness shall be given maximum credit. Transitions should be smooth and responsive.

Horses will be faulted for:

- Short, quick, vertical strides
- Break of gait
- Wrong lead
- Excessive speed or slowness at any gait
- Failure to take appropriate gait when called for
- Stumbling
- Being dull, lethargic or emaciated
- Carrying head too high or low (poll above or below withers)

# Miscellaneous Hunter Classes

---

Points earned in these classes count toward Prairie Cup (or Heritage) Awards. If multiple heights are jumped in the same class, results must indicate what height was jumped by each competitor.

## Hunter Derby

1. The purpose of the Hunter Derby is to:
  - a. Return hunters to their hunt field roots.
  - b. Take hunters to the International level.
  - c. Promote hunters as a spectator sport.
  - d. Revive traditional horsemanship and add excitement to the hunter ring.
2. Courses are designed to more closely resemble the hunt field. There are fewer ground lines, taller, narrower fences, ditches, gates, banks, walls and hedges. Most derbies are set and run in the jumper ring.
3. In a Hunter Derby, the approach to the jumps varies greatly. There may be lines that are short, long or serpentine and the decision on how to ride these is completely negotiable.
4. Riders are rewarded for choosing more difficult routes, which can include optional jumps.
5. Hunter Derbies differ from traditional hunter classes primarily in the construction of the fences and the track between them.

## Hunter Classic

1. This class is only open to horses that have shown in at least one other hunter class at the competition.
2. Competitors are allowed to walk the course prior to jumping.
3. The class is to be shown over two hunter rounds.
  - a. The first round will consist of approximately 10 fences and each participant will be given a numerical score (out of 100). The top eight horses will return for the second round.
  - b. The second round is a shortened course. The top eight will return in reverse order of their numerical score achieved in the first round (lowest score will go first).
  - c. Final placings will be determined by adding the scores of both rounds.
  - d. Horses must be stripped and jogged for soundness.

# Hunter Special

The Hunter Special is a class that is run similar to the Classic except that it is only one round. Scores will be announced after each round and awards will be given after all competitors have completed their course.

# Prairie Cup Hunter Course

Jumps 1–8

Large Arena (100 x 200)

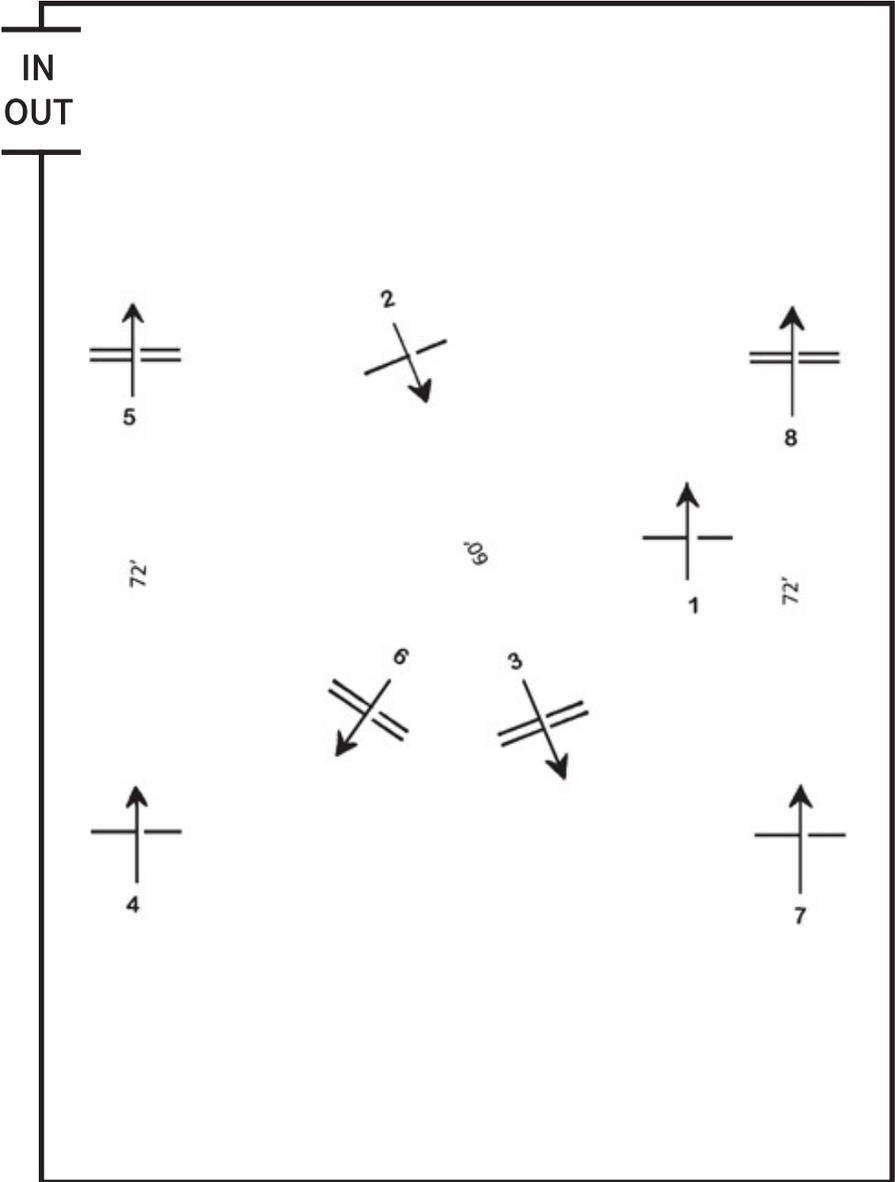

# Jumper Division

---

## General

A jumper is generally a horse that has more power and energy than a hunter. Because only jumping ability is scored, conformation, manners, and way of going are critical only as far as they affect the horse's soundness and its ability to jump. Classes may run as one or be limited to either horses or ponies.

Prairie Cup jumper divisions are classified according to the maximum height of the fences to be jumped.

A jumper competition is a timed event and will be set to run in either an indoor or outdoor arena. The rider will test their horsemanship skills by jumping a series of obstacles that allow them to demonstrate the freedom, energy and obedience of their horse. The obstacles in a Prairie Cup show should be set so that they are simple and yet provide enough challenge to adequately test the horse's jumping skill. Jumper fences are typically airier than hunter fences and provide less of a ground line. The rails and standards are often brightly colored, and the jumps may vary in width (some being narrow). Courses may vary in their degree of difficulty by changing how a fence is built, whether it is a vertical or an oxer, or where the fences are in relation to the in-gate. The slope and shape of the ring may also influence the degree of difficulty within a course.

**All Prairie Cup approved Jumper classes under 0.90m will not be run as Speed classes**

**A horse/rider combination may compete in a maximum of three consecutive heights per day.**

**A horse may compete in a maximum of four over fences classes per day which applies to combined Hunter and Jumper classes including specials, classics, derbies, stakes, medals, or equitation over fence (not including Hunter warm ups, Jumper clear-rounds and hors concours rounds). Hunter classics and hunter specials that are 2 round classes will count as one over fences class. Jumper classes that include a jump off will count as one over fences class.**

**"Hors concours" rounds are allowed at the discretion of the judge and/or show committee. Hors concours riders will pay a regular entry fee and will follow all rules pertaining to the competition. They will not be eligible for awards. A horse or pony that has competed "HORS CON-**

**COURS” is not permitted to be judged in the same ring on the same day. A horse or pony may only compete “HORS CONCOURS” once in the same ring on the same day.**

**A horse is limited to one round per class and may not be ridden by more than one rider in that class.**

**An exhibitor may ride up to three different horses in any one class.**

## **Headgear**

At competitions offering jumper classes, approved headgear (helmet) with safety harness permanently affixed to the helmet is compulsory for everyone riding anywhere on the competition grounds. It is mandatory that the protective headgear meets the A.S.T.M./SEI standards. At competitions offering jumper classes, anyone mounted on a horse on the competition grounds must wear approved helmets with safety harness correctly fastened, at all times. Protective headgear must be certified under one of the following standards: ASTM (American Society for Testing Materials), SEI (Safety Equipment Institute, Inc.), BSI/BS EN (British Standards Institution), EN (European Union Standards), As/NZS (Austrian/New Zealand Standards), or CE VGI 01.040 2014-12.

## **Safety/Medical Services**

It is mandatory that all competitions where persons are required to jump over obstacles have Emergency Medical Services on site. There should be a minimum of advanced first aid and basic cardiac life support (BCLS) provided. The presence of an ambulance is not required. A crisis response plan should be prepared in advance by the show committee.

## **Number Rule**

At Prairie Cup shows offering jumper classes competitors are required to wear their bridle/back numbers at all times when the horse is being schooled, whether mounted or not.

## **Tack & Equipment**

1. Draw reins or German martingales are not permitted for Junior, Adult Amateur, Non-pro and Pony riders.
2. Standing martingales, German martingales and draw reins secured at the neck are permitted where the height of the fence does not exceed 1.15 m.
3. There are no restrictions on saddlery.
4. Blinkers are forbidden.
5. Reins must be attached to the bit(s) or directly to the bridle. Loop reins are permitted.
6. Gags and hackamores are allowed.
7. Stirrup irons must hang freely from the bar of the saddle and outside of the flap. There must be no restrictions or attachments.
8. Whips must be un-weighted and must not exceed 75cm (30").
9. Leg wraps and/or boots are permitted.

## **Attire**

1. Competitors should be suitably and neatly dressed in breeches, boots, shirt and tie, choker or stock collar and coat. Half chaps (preferably matching boot color) are permissible.
2. In hot weather, competitions may permit riders to wear 'dress' or riding shirts with or without chokers and ties or open neck polo shirts without jackets.
3. An approved helmet (as listed above) is mandatory.

# Course Design

1. **The SHF insists on the use of course designers when setting over-fences classes at a Prairie Cup level competition. Please contact the SHF office for more information and a list of approved course designers.**
2. Good course design is of primary importance when running jumper classes. A properly designed course should allow a well-trained horse and rider to demonstrate their skill and ability. In the first round of a jumper class, there should be a reasonable percentage of clear rounds. If this is not the case, the course is determined not well suited for the caliber of horses competing. For example, if the course is too difficult, there will be no jump-off rounds and if not difficult enough, it may entail many time-consuming jump-off rounds to determine a winner.
3. Jumps such as triple bars are readily negotiated while obstacles with parallel rails provide a greater degree of difficulty and will provide a harder test for the horse. Competitions should include as many different types of obstacles as possible. These can be changed and rearranged for different classes.
4. Prairie Cup show committees should ensure that all equipment used in the show is in good repair and meets required safety standards.
5. All fences on the show grounds must use approved breakaway cups (plastic cups and pins or plastic cups on tracks). Steel and wooden pegs used to hold gates, poles and planks are not permitted. Prairie Cup shows may use standards with tracks or standards with drilled holes. Standards must be drilled in maximum of 7.5 cm (3") increments.
6. Distances between jumps should be based on a 12-foot stride length and must include a 6' take off and a 6' landing distance. The relationship of the jumps (whether or not they are singles or in a combination) will affect the horse's natural jumping arc, the length of its stride and its speed.
7. Flags to indicate direction (red flag on right side and white on left) are required on all jumps, including warm-up fences.

8. **Measuring the Course:** The course is the track the competitor must follow between the starting flag and the finishing flag. The length must be measured accurately to the nearest meter, taking account of the normal line to be followed by the horse. This line must pass through the center of each obstacle on course.
- The total length of the course in meters may never exceed the number of obstacles in the course multiplied by 60.
  - The starting line may not be more than 25 meters nor less than 6 meters from the first obstacle.
  - The finishing line may not be more than 25 meters or less than 15 meters outdoors (10 meters indoors) from the last obstacle.
  - The start and finish lines must be marked with an entirely red flag on the right and an entirely white flag on the left.
9. Should the condition of the ground become bad before the first horse of the competition starts, the show committee and course designer in consultation with the judge may alter the speed of the course.

## **Class Conduct**

- A horse is judged solely on performance over a pre-designed jumper course.
- The course must be posted at least 30 minutes before the start of the class.
- The order of go must be posted at least 30 minutes before the start of the class. Where a rider has more than one horse in the class, the order of go should provide at least five horses between the rider's horses. The other horses will be moved up in order to satisfy this rule.
- The time allowed is based on the actual length of the course, should be generous, and must be given for each class. The time limit is equal to twice the time allowed.
- Time is recorded in seconds and one/hundredths of a second.

6. Timing:
  - a. Timing is the responsibility of the judge.
  - b. Electronic timing should be used if possible.
  - c. At least one back-up timer with a stopwatch must record every jumper round. Without electronic timing, two timers are preferable, averaging the times for the official time.
  - d. A judge acting alone cannot act as the timekeeper as well.
7. In a series of jumps, a normal distance allows for multiples of 12 feet between the fences. The stride of a normal horse is 12 feet, and a 24 foot distance between two fences allows for one stride (6 foot takeoff + 12 foot stride + 6 foot landing). This may be slightly shortened to accommodate green horses or those with a shorter stride. Distance may not be changed during the class.

24'	1 Stride	60'	4 Strides
36'	2 Strides	72'	5 Strides
48'	3 Strides	84'	6 Strides

8. Obstacles may be one single jump, or a combination of jumps in a line.
9. The maximum distance between two fences within a combination is 36'. A combination may consist of 2 or 3 fences in a line.
10. Late and post entries go first in a class when they are accepted after the order of go is drawn.
11. The judge's whistle or bell signals the start of a round.

#### 45 Second Rule

Once the bell has rung the rider has a 45 second countdown to cross the start line in the correct direction. The time awarded to the rider starts running either upon crossing the starting line or upon expiration of the 45 second countdown, whichever occurs first. It extends to the moment when the mounted rider crosses the finishing line in the correct direction, after having jumped the last obstacle. Taking more than 45 seconds to jump the first obstacle after the time of the round has started constitutes Elimination.

12. A whistle or bell is used to communicate with the riders to:
  - a. Give permission to walk the course
  - b. Start the competition
  - c. Stop the clock during a knockdown or other incident on course

13. Flags are used on the jumps to indicate the approach to be taken. Red flags indicate the right-hand side, and white flags the left-hand side of the jumps.

## **Jump Off**

1. Only competitors who are in equal first place after one or several preliminary rounds of the same competition may take part in a jump off.
2. The order of starting in the jump off must remain the same as the order of starting for the original round.
3. The obstacles in a jump off may only be increased in height and spread if those competitors involved have had no jumping penalties in the previous round.
4. The course may be shortened to a minimum of 6 fences that may be raised and/or spread as specified above.
5. The jump off must be conducted under the same rules and table as the original class.
6. A maximum of two additional single obstacles may be added to the course of a jump off. Both obstacles must be on the course during course inspection. These obstacles may consist of two oxers or two verticals or one oxe and one vertical.

# Penalties

## PC Table A

First disobedience	4 penalties
Obstacle knocked down while jumping	4 penalties
One or more feet in water jump or on the tape	4 penalties
First fall of horse or rider or both in class	Elimination
Refusal, plus knocking down an obstacle	4 penalties + time correction
Second disobedience	Elimination
Exceeding the time allowed	One penalty for each second commenced <del>1 penalty for every 4 second interval (or started interval) over the time allowed</del>
<del>Exceeding the time allowed in jump off</del>	<del>1 penalty for each second</del>
Exceeding the time limit	Elimination

1. Penalties for disobediences accumulate not just at the same obstacle but throughout the entire round.
2. Knockdowns: An obstacle is considered knocked down when the height is lowered by the horse or rider through contact with a rail or standard.
3. Adding together the penalties for faults at the obstacles, and the time penalties give the score obtained by the competitor for the round.
4. Time may be used as a deciding factor to separate equality for first place and/or lower places according to the specifications given for the competition.

## **Disobediences**

1. Refusal: When a horse stops in front of an obstacle (whether or not it is knocked down). If the horse is moved toward the obstacle but does not attempt to jump, it is considered another refusal.
2. Run-out: When a horse evades or passes the obstacle to be jumped.
3. Loss of forward movement: When a horse fails to maintain the trot or canter after beginning the course.
4. Unnecessary circling on course: When a rider circles his/her horse in such a manner that its original track between two consecutive obstacles (anywhere on course) is crossed. The exception to this is if the horse is retaking an obstacle after a refusal or run-out.

## **Elimination**

- Two disobediences including refusal, stop, run-out, or extra circle
- Bolting from the arena
- Off course
- Jumping an obstacle before it is reset
- Fall of horse and/or rider. A horse is considered to have fallen when shoulder and haunch on the same side touch the ground. Rider may not remount.
- Starting (or continuing) on course before the signal to proceed
- Jumping an obstacle before crossing the start line
- Leaving the arena before finishing the course
- Striking a horse more than twice

## **Pony Jumper Division**

1. Competitions may offer pony jumper classes or divisions.
2. Pony height may not exceed 14.2 HH and may be measured if height is in question.
3. Classes should be run under Table A.
  - a. Immediate jump offs are permitted.
  - b. Maximum height for pony jumpers is 0.90 m and maximum spread is 1.00 m.

# Prairie Cup Jumper Course 1

Indoors (or small ring) - 100m x 200m

325 m/m

Jumps 1-9

Distance: 350 m

Time Allowed: 65 seconds

Jump Off: 4b, 1, 2, 3, 8, 9a, b

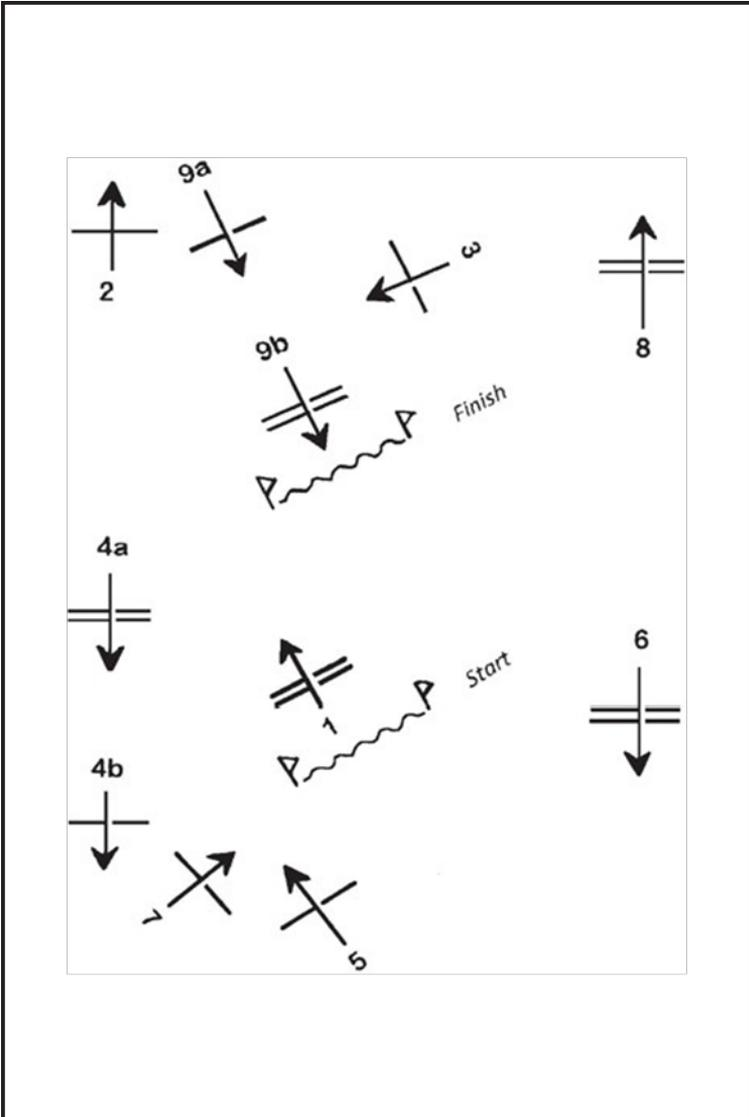

# Prairie Cup Jumper Course 2

Outdoors (large ring)

350 m/m

Jumps 1-10

Distance: 460 m

Time Allowed: 79 seconds

Time Limit: 158 seconds

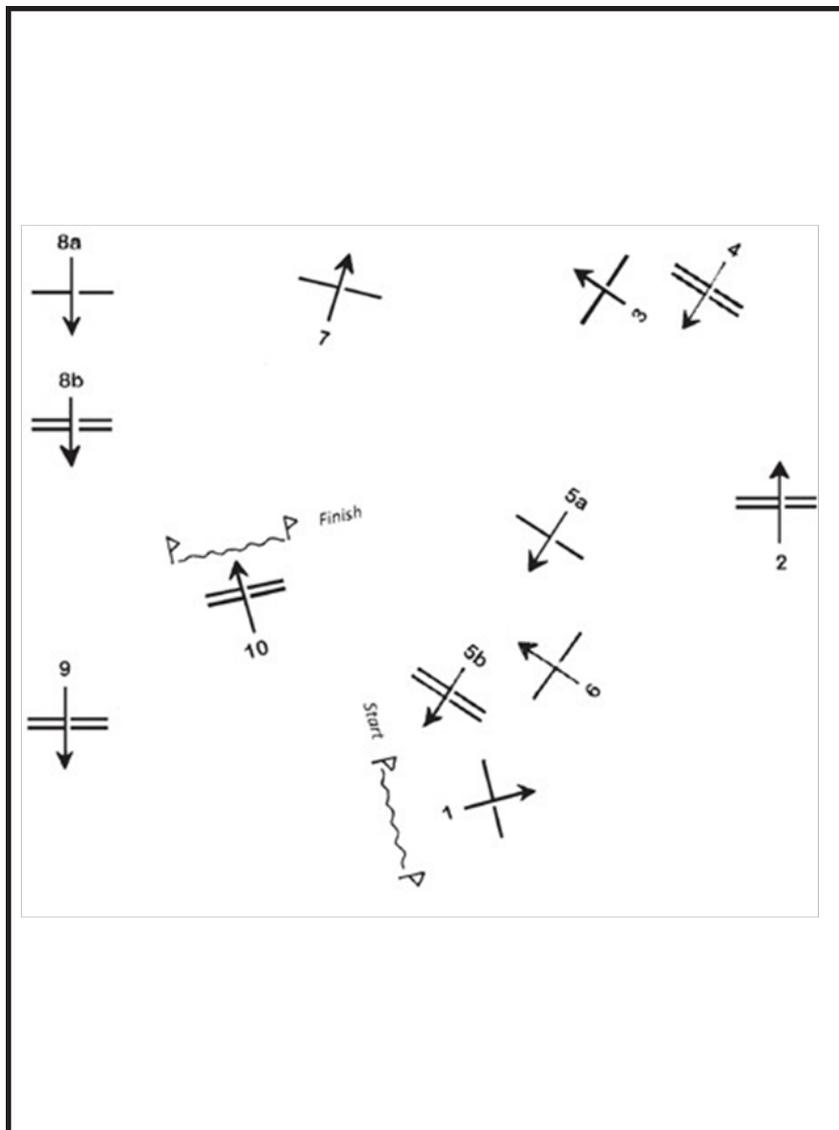

# Reining Division

---

To rein a horse is not only to guide it, but also to control its every movement. The best reined horse should be willfully guided or controlled with little or no apparent resistance and dictated to completely.

Prairie Cup reining classes are to be hosted following the most current Rules of NRHA and must be judged by an NRHA judge.

## **Prairie Cup Reining – Class Clarification**

- Youth, Non-Pro, and Open classes will be eligible Prairie Cup classes.
- Rookie, Green, and Novice classes will not be eligible.
- The horse/rider's best score from Youth, Non-Pro, or Open classes at a show will be used as the horse/rider score from that show, in that Division.

Prairie Cup Awards will be given in the following divisions:

- Open – Champion and Reserve Champion
- Non-Pro – Champion and Reserve Champion
- Youth (18 and under) – Champion and Reserve Champion

Only scores in NRHA or SRHA competitions will count towards Prairie Cup awards.

Refer to current year's NRHA rulebook for patterns.

<b>When you Know</b>	<b>Multiply By</b>	<b>To Find</b>
Inches	2.54	Centimeters
Centimeters	0.39	Inches
Meters	3.3	Feet
Feet	0.3	Meters

2'3"	0.70 m
2'6"	0.75 m
2'9"	0.85 m
3'0"	0.90 m
3'3"	1.00 m
3'6"	1.10 m
3'9"	1.15 m
4'0"	1.20 m
4'3"	1.25 m
4'6"	1.30 m



North Battleford Location



Battlefords  
Animal Hospital



